

MPPT SOLAR CHARGER CONTROLLER

USER MANUAL



■ MPPT series

Model;TYC-12/24/48V20-60IR/AL

Product Description

Thank you for choosing the TY series MPPT controller. It is a new generation of MPPT controller, and its the research and development is based on the latest technology, It is a representative of the latest level of development of PV technology products. Many Excellent performance of MPPT products are shown as follows:

- Excellent cooling design and intelligent control of the cooling fan.
 - The innovative maximum power of tracking can significantly improve the energy efficiency of systems, the conversion rate is $\geq 97\%$.
 - Quickly scan the entire I-V curve for a few seconds to track the maximum power point.
 - Sealed, colloid, open of lead-acid battery and lithium battery series charging program optional.
 - The controller has the automatic protect function for overcharge, over discharge, overload, short circuit etc.
 - The Rs485 communication interface can do multi-machine communication. The communication distance is 1KW, that can communicate with PC board, in order to check the controller operating parameters.
- This controller is used in off-grid solar system (independent system),it can automatically adjust the charge and discharge. The MPPT controller utilizes an advanced tracking algorithm to obtain the maximum power of the PV module to charge the battery. At the same time, the low voltage disconnect (LVD) function prevents battery damages caused by excessive discharge. The MPPT controller's battery charging process is optimized to extend battery life and improve system performance. Its comprehensive self-test function and electronic protection function to avoid the controller damage caused by the installation error and system failure. Although the TY-series MPPT controller is easy to operate and use, but in order to make better use all the functions and improve your PV system, please read this manual carefully.

The Features of the Maximum Tracking Rate

The TY-series MPPT controller utilizes maximum power point tracking technology to extract the maximum power from the solar array to charge the battery. The maximum power point tracking mode is full automatic and no user adjustments are required. When the maximum power point of the array changes with ambient conditions, the controller automatically tracks the maximum power point of the array to ensure that the maximum energy of the day is obtained from the solar array.

• Current Enhancement

In most cases, the maximum power point tracking technology will increase the charging current of the system. Assuming a system may have 10 amps of current flowing from the solar array into the MPPT controller, then will have 12 amps of current flows from the MPPT controller to the battery. MPPT controller does not generate current! The energy input to the MPPT controller is equal to its output energy. Since the power is the production of voltage and current (volts x amperes),

The following situation was established:

(1)MPPT controller input energy = MPPT controller output energy

(2)Input voltage x input current = output voltage x output current

* Suppose the efficiency 100%, ignoring the power loss of during wire and conversion. If the maximum power point voltage V_{mp} of the solar array is larger than the battery voltage, the battery charge current must be proportionally larger than the solar array output current, so that the input and output power can be balanced. The greater difference between the V_{mp} voltage and the battery voltage, the greater current enhancement. Current enhancement is extremely important in the system, because the maximum power point V_{mp} voltage of solar panel in a system is usually higher than the battery voltage.

10. Quality guarantee

Products with failure during the period of quality guarantee, our company will supply free maintenance service or replacement of new products.

Evidence

During quality guarantee, our company requires customer show purchase invoice and date of the products. At the same time , logo on the products should be clear and distinct, if not, we have the right to refuse.

Conditions

- Substandard products after replacement should be handled by our company.
- Customer should leave reasonable maintenance time to repair the fault equipment.

Responsibility immunities

Our company have the right to refuse provide quality guarantee on the conditions below:

- The whole machine or components have exceeded free guarantee period.
- Transportation damage
- Incorrect installation, modification or use
- Operated beyond very harsh environment illustrated in this manual
- Machine failure or damage caused by maintain, change or disassemble by non-our company services.
- Damages caused by abnormal natural environment

Products failure caused by above situations, customers should pay for maintenance service.



Illustration

Any variation in product dimension and parameters will be subject to our company latest information, without prior notice.

9. Maintenance and clean

8.1 Replacing the fuse

Due to the high temperature or other failures caused by the broken fuse, that need to correctly replace the fuse; It should from the interface to remove the broken fuse, install a new fuse, then check whether the connection is correct or not, and finally install the equipment. (the fuse is near the interface)

8.2 Clean the vent heat sink

Regularly clean the fan vents and internal heat sinks, wipe with dry or damp cloth;

Note: Do not use detergent or corrosive solvent to clean, do not allow liquid flows into the machine, please ensure that the ventilation holes of the equipment are not blocked.

The advantages of maximum power tracking

• The Advantage condition to compare with the traditional controller

When the system charging, the traditional controller needs directly connect the solar array to the battery. This requires that the solar array operate normally below the V_{mp} voltage range. For example, in a 12V system, the battery voltage range usually is 11-15V, but the solar array V_{mp} voltage usually is about 16-17V.

The following figures show the current, voltage and output power curves for a typical standard rated voltage of 12V off-grid solar battery.

The current and voltage of 12V battery

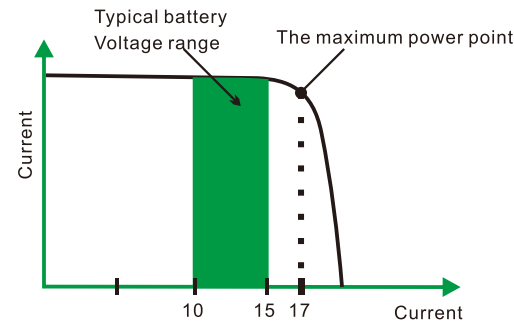

The output power of 12V battery

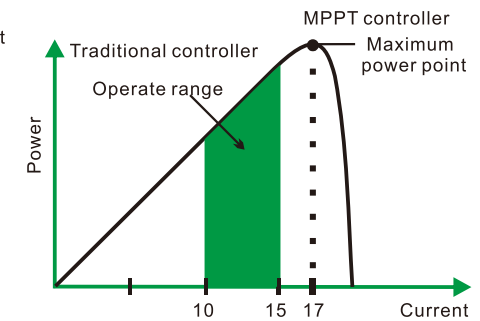

Standard 12V solar battery I-V curve and output power figures

Solar PV array maximum power point voltage is the maximum voltage of out power (Ampere x voltage), it is in the "knee" of solar PV array I-V curve as shown above the left figure. Since the traditional controller does not always operate in the PV array V_{mp} , the energy is wasted, which can be used to charge the battery and supply power to the system load. The greater difference between the battery voltage and the V_{mp} of the solar PV array, the more energy is wasted. The MPPT controller will always operate with the maximum power point, that can reduce energy waste to compare with traditional controller.

• The factors of limit the maximum power point to track the efficiency of the controller are:

The V_{mp} of the solar PV array will decrease as the temperature of the array increase. In hot weather, V_{mp} may be close to or even lower than the battery voltage. In this case, the MPPT controller will have less or can't obtain the energy compared to traditional controller. However, once the nominal voltage of the PV module is higher than the battery voltage, the V_{mp} of the PV module will always be higher than the battery voltage. In addition, the MPPT controller has a significant advantage even in hot weather, due to the reduced current of the solar array and the saving wire.

1. Attention	1
2. Safety instructions	1
3. Open package and check	3
4. Installation	3
4.1 Installation location	3
4.1.1 Dimension	3
4.1.2 Environment condition	4
4.1.3 Safety distance	4
5. The connection of MPPT controller	4
5.1 The component of PV system	5
5.2 Wire connection	5
5.2.1 Wiring steps	5
5.2.2 Battery connection	5
5.2.3 DC load connection	6
5.2.4 PV module connection	6
5.2.5 The temperature sensor and the MPPT controller connected to the PC	7
5.3 Power test run	8
6. MPPT operate instructions	9
6.3 LCD display description	9
6.3.1 Main interface description	9
6.3.2 Check the main interface	9
6.3.4 Main interface	10
6.4 Parameter setting	12
6.4.1 Language setting	12
6.4.2 Time and date adjustment	12
6.4.3 Contrast adjustment	12
6.4.4 Brightness adjustment	13
6.4.5 Sound setting	13
6.4.6 Record query	13 14
6.4.7 Delete record	14
6.4.8 System information query	15

8 . Remove faults

When the controller is abnormal, check the following items before contacting your customer service representative.

Fault exception	Remove fault
MPPT controller do the electricity for the first time, the malfunction prompt is battery voltage beyond the normal identification range.	1. Please check the battery voltage whether is in the system voltage identification range or not. (Details see the system voltage identification range of technical parameters) 2. Set the rated battery voltage grade manually. (Details see the rated battery voltage setting of operatin parameter setting)
Fault prompt: Over temperature protection	1. Check the cooling fan whether is damaged, or ventilation holes are blocked by debris. MPPT controller should be installed in a ventilated environment. 2. Reasonable PV module configuration can improve the conversion efficiency and can reduce the temperature rise (Technical parameters of PV module configuration)
Fault prompt: Over discharge protection	The battery is out of power
Fault prompt: No external temperature sensor has been detected	1. Is the external temperature sensor connected? 2. Check if the sensor is in poor contact.
Charge indicator light does not light, no charge current and charge power display	1. Whether the PV module voltage is within the MPPT operating voltage range. 2. Check the charge voltage of the system information if is correct or not. 3. Correct the charge voltage parameter or restore the factory setting to restart the MPPT controller
The charge indicator is sometimes light off, the charge current is sometimes absent	This situation is generally in the cloudy weather or evening when the lack of light, is a normal phenomenon.
No power curve and current curve display	Check the time and date displayed by MPPT controller are consistent with your local time and date.

If the problem continues after check according to the above table, please contact the customer service:

Please provide the following information:

1. Equipment information: model, order No., series No.(label on backboard);
2. A detailed description of the problem (such as the use of system type, the problem is accidental or appear frequently, and the situation of light indicator, display etc.)

PV power – Conversion efficiency curve



- 6.4.9 DC output setting 15
- 6.4.10 Communication setting 16
- 6.4.11 Operation parameter setting 16
 - 6.4.11.1 Battery type setting 17
 - 6.4.11.2 Battery rated voltage 17
 - 6.4.11.3 Charge voltage setting 18
 - 6.4.11.4 Charge current setting 18
 - 6.4.11.5 Discharge limit voltage setting 19
 - 6.4.11.6 Factory reset 19
 - 6.4.11.7 Password 19
- 7. Technical parameters 20、21、22、23
- 8. Remove fault 24
- 9. Maintenance and Clean 25
- 10. Quality guarantee 26

1 . Attention

This manual introduce the relevant operation of MPPT solar charger controller

1.1 Availability

This manual is used for all of TY-series MPPT charger controller



1.2 Target groups

This manual is appropriate for installer and operator

1.3 Before installing and using this controller, please read the safety information carefully in this manual. And hold for safekeeping, in order to use it next time



1.4 Safety sign descriptions

The following are the descriptions of sign's type in this manual

	<p>Warning! “Warning” means that if continue use, it might result in the machine fault or accident.</p>
	<p>Danger! “Danger” means that if continue use, it might result in the machine and accident.</p>
	<p>Note! Please read this operate instruction carefully, in order to manipulate this MPPT controller more efficiently.</p>

2. Safety instructions

2.1 Safety attention

	<p>Warning!</p> <ul style="list-style-type: none"> • The range of input voltage of this controller is large, if you do not carefully operate, it might cause personal injury • All operation in this MPPT system should be conducted by technical personnel. • These people do not allow to operate this system: Children, Disabled, Handicapped or the operator who lack of relevant experience and knowledge. • Keep away from children
	<p>Warning! Over heat shell</p> <ul style="list-style-type: none"> • Please install in a well ventilated environment
	<p>Warning! Radiation can damage health</p> <ul style="list-style-type: none"> • Do not stay for a long time at a distance of less than 200 centimeters near the solar charge controller

Parameter

Model	12/24/48V					48/96V		
	TYC-20IR	TYC-30IR	TYC-40IR	TYC-50IR	TYC-60IR	TYC-40A96	TYC-50A96	TYC-50A96
	TYC-20AL	TYC-30AL	TYC-40AL	TYC-50AL	TYC-60AL	TYC-40AL96	TYC-50AL96	TYC-50AL96
Features								
Dimension	See the package box							
G.W (kg)	See the package box							
N.W(kg)	See the package box							
Mechanical protection type	IP21							
Environmental requirement								
Humidity	0~90%RH (not condensation)							
Elevation	0~3000M							
Working temperature	-20℃~+40℃							
Storage temperature	-40℃~+70℃							
Atmospheric pressure	70~106kPa							
PV module configuration								
System voltage(battery voltage)	PV module load voltage(recommend value) (recommend value)							
12 System	solar panel 18~60V (30V *1pcs in series , 36V *1pcs in series)							
24V System	solar panel 36~72V (30V *2pcs in series , 36V *2pcs in series)							
48V System	solar panel 72~144V (30V *5pcs in series , 36V *4pcs in series)							
96V System	solar panel 144~180V (30V *6pcs in series , 36V *5pcs in series)							



Parameter

Model	12/24/48V					48/96V		
	TYC-20IR	TYC-30IR	TYC-40IR	TYC-50IR	TYC-60IR	TYC-40A96	TYC-50A96	TYC-50A96
	TYC-20AL	TYC-30AL	TYC-40AL	TYC-50AL	TYC-60AL	TYC-40AL96	TYC-50AL96	TYC-50AL96
Float charger current(Lead acid battery)	20A	30A	40A	50A	60A	40A	50A	60A
Rated current	22A	32A	42A	52A	62A	42A	52A	62A
Float charge current Charge voltage (lead acid battery)	12V System	13.75V	can custom float voltage					
	24V System	27.5V						
	48V System	55V						
	96V System	110V						
Equalizing Charge voltage (lead acid battery)	12V System	14.2V	can custom Equalizing voltage					
	24V System	28.4V						
	48V System	56.8V						
	96V System	113.6V						
Temperature coefficient	±0.02%/°C							
Automatic Temperature compensation	14.2V- (Maximum temperature -25°C) *0.3							
Output Voltage Regulated Accuracy	=±1.5%							
LCD Display	More details shown in LCD instruction							
LED Display	Charging indicator,DC output indicator							
PC (communication port)	Rs485(Optional)							
Protection								
Low input voltage	See the input features							
High input voltage	See the input features							
Input polarity reverse	yes							
output polarity reverse	yes							
Short circuit	After long-term short circuit,the short circuit fault can eliminate fro the recovery							
Temperature	+85°C							
heat protection	Over +80°C to reduce power output							
Other parameters								
Audible noise	=50dB							
Heat-dissipating method	Forced air cooling,fan speed regulated by temperature.When the internal temperature is low,the fan runs slowly or stops;when the controller stops working,the fan stops running;							
Coomponent	Imported materials,in line with EU standards all the temperature of the electrolytic capacitor rated temperature is not less than 105°C							
smell	Do not produce odor and harmful to the health of the smell							
Environmental requirement	Meet the regulation of 2002/95/EC; No cadmium,hydride and fluoride;							

Safety instructions



2.2 Safety sign illustration

This chapter shows the illustrations for all display sign on product labels

Sign	Instructions
	Risk of electric shock When the system is disconnection, the energy stored in the capacitor will still exist until 5 minutes, within this 5 minutes, please do no touch the internal components.
	Do not self-repair the parts inside the machine, do not try to remove the cover; The operation and maintenance of the product should be conducted by professional personnel; Please use the insulation tool when you operate or repair it, in order to reduce the risk of harm.
	Note sign for over heat The solar charging controller becomes heat during the operation. Please avoid to touch it during running; Prohibit putting anything on the product or blocking the fan vents.

2.3 Safety instructions

- Please remember below information when you use it, to avoid fire, lighting stroke or any other personal injuries

	Warning! Make confirmation for the input direct current is less than or equal to the maximum voltage rate, over voltage may cause the permanent damage to the solar controller. Above situation not included in the warranty period. This section includes the instructions of safety and operation. Read and save it for use next time.
	Warning! If the technician want to maintain or clean the solar controller or connect to the circuit, it must be follow the relevant steps.

- Before using the solar charge controller, please read all instructions, warning signs and the corresponding sections of this manual
- Please use the parts are recommended or sold by our company;
- In order to avoid the risk of fire and electric shock, please make ensure that the existing lines have good conditions and suitable wire size. Do not operate under the damage of solar controller and unqualified wire;
- Do not disassemble or attempt to repair the solar charge controller by yourself, it may result in further damage and the risk or accident, also will loss the warranty;
- Keep away from flammable and explosive materials, to avoid caused the fire;
- The installation location should be kept away from moisture or corrosive substances;
- In order to reduce the probability of short circuit, the technician must be used the insulation tool to operate the equipment.

3 . Open package and check

3.1 The product includes below accessories

Item	Quantity	Remark
Controller	1	
Manual	1	
Temperature sensor	1	

If you find missing parts, please contact the dealer.

3.2 Check the damages in transit

After receiving the product, please do not sigh before open box and checking whether the product deformation or shell cracks or other obvious crash phenomenon, if there is any damage please refuse to sign, and then contact the dealer.



3.3 Identify the MPPT charger controller

There is a label in the side of the controller, if you found that it is not to match your purchase, please contact the dealer.

4、Installation

This installation should be conducted by professional personnel

4.1 Installation location

	<p>Danger:</p> <p>The charging controller case will become hot during operation</p> <ul style="list-style-type: none"> Do not install on flammable building materials; Do not install nearby highly flammable materials; Do not install in potentially explosive areas; Do not install the charge controller in a place where the sun is exposed directly, to avoid the loss of overheating.
	<p>Warning!</p> <ul style="list-style-type: none"> Due to built-in thermal storage components, please do not open the shell and touch it during the operation.

4.1.1 Dimension

Model	TY-AL series 20A/30A	TY-AL series 40A/50A/60A
Size	L*W*H 208mm*146mm*76mm	L*W*H 245mm*174mm*76mm
Model	TY-IR series 20A/30A	TY-IR series 40A/50A/60A
Size	218mm*154mm*65mm	260mm*192mm*80mm

7. Technical parameters

Model	12/24/48V					48/96V			
	TYC-20IR	TYC-30IR	TYC-40IR	TYC-50IR	TYC-60IR	TYC-40A96	TYC-50A96	TYC-50A96	
	TYC-20AL	TYC-30AL	TYC-40AL	TYC-50AL	TYC-60AL	TYC-40AL96	TYC-50AL96	TYC-50AL96	
Charge mode	MPPT Automatic maximum power point tracking								
Charge method	3 stage :constant currenet(MPPT),equalizing charge,float charge								
System type	12/24/48V Automatic identify、 48/96V Automatic identify (36V、 72V manual setting)								
Short -start time	=10S								
Dynamic response time to recover	=500us								
Quiescent dissipation	=2W								
Machine efficiency	=96.5%								
PV module utilization	=99.97%								
Limit the input voltage	DC170V(96V: 225V)								
input over-voltage protection points	DC175V(96V:230V)								
input over-voltage recovery points	DC170V(96V:225V)								
Identify range of battery voltage	12V	DC9V-15V							
	24V	DC18V-30V							
	48V	DC36V-60V							
	96V	DC72V-120V							
Input characteristics									
MPPT working voltage range	12V	DC18V-150V							
	24V	DC34V-150V							
	48V	DC65V-150V							
	96V	DC130V-180V							
Input low voltage protection points	12V	DC16V							
	24V	DC30V							
	48V	DC60V							
	96V	DC120V							
Input low pressure recovery points	12V	DC18V							
	24V	DC34V							
	48V	DC65V							
	96V	DC130V							
The maximum input power of solar	12V	280W	420W	570W	700W	900W	48V2270W/96V5540W	48V2800W/96V5600W	48V3400W/96V6800W
	24V	550W	840W	1130W	1400W	1700W			
	48V	1100W	1650W	2270W	2800W	3400W			
Output characteristics									
Optional battery type(the default is lead-acid battery)	Lead-acid battery,colloidal batteries ,liquid batteries ,lithium batteries (Also can be customized for other types of battery charging)								

6. MPPT operate instructions

6.4.11.5 Discharge limit voltage setting

Under the operation parameters interface, press the DOWN key to select the discharge limit setting and press the ENTER key to enter the discharge limit setting. Press the UP key to move the cursor, press the DOWN key to enter the value, press the ENTER key to confirm the save, after hear the continuous tone and press the MENU key to return to the previous menu.

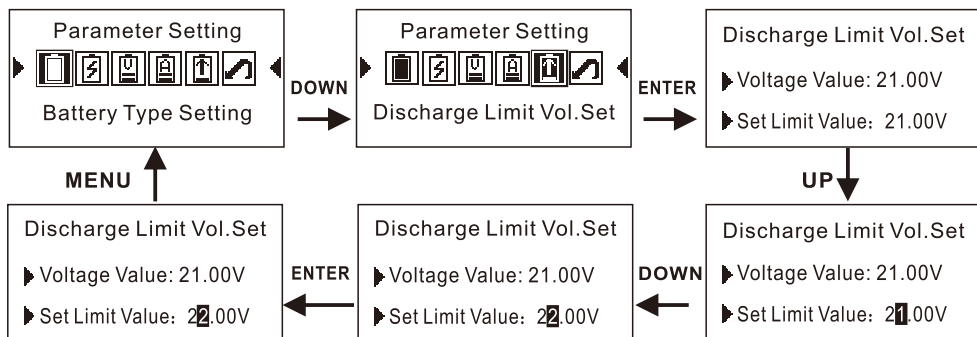

6.4.11.6 Factory Reset

Under the operation parameters interface, press the DOWN key to select the factory reset and press ENTER to enter the factory reset. Press the DOWN key to select whether to reset the factory reset or not, press the ENTER key to confirm the save, and press the MENU button to return to the upper layer interface.

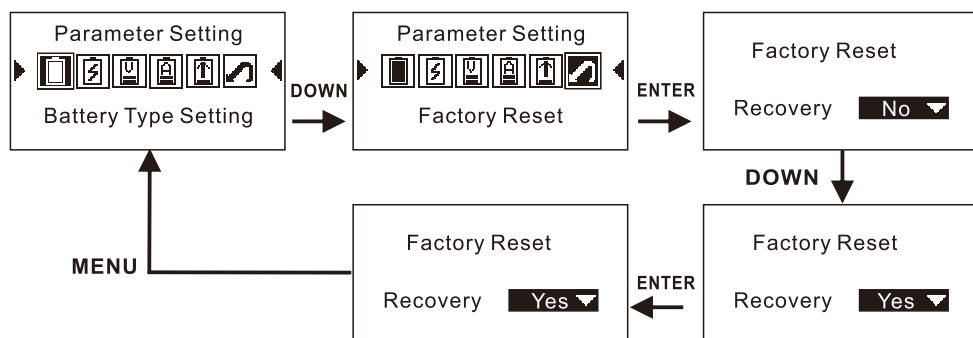

i When the operating parameters are set incorrectly to cause MPPT controller not work, the operating parameters can be restored to the factory settings.

6.4.11.7 Password

Press DOWN key 3 times and press UP key 3 times, then press ENTER key to enter the operation parameter

Installation

4.1.2 Environment condition

- Install on a solid surface
- The installation location must be accessible at any time
- The installation location can be removed at any time
- To ensure the optimal working environment, the ambient temperature should be -20°C~50°C
- Do not install the charge controller in a direct sunlight, to avoid power loss due to overheating.

4.1.3 Safety distance

Observe the following safety clearance to ensure that other equipment or objects are not within this range to ensure adequate cooling space.

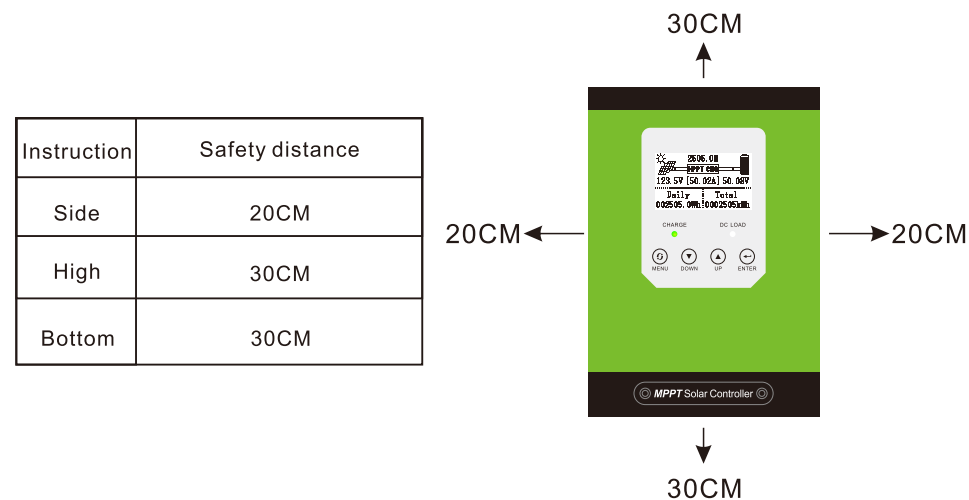

5. MPPT controller connection

	<p>Danger! If the high voltage input and operation is not correct of the solar charge controller, it may lead to life-threatening.</p> <ul style="list-style-type: none"> • Disconnect the solar panel array should use a circuit breaker and avoid accidental activation; • Disconnect the circuit breaker and make sure it can not be reconnected; • Make sure for that there is no voltage present in system
	<p>Warning! Over-voltage can damage the system</p> <ul style="list-style-type: none"> • Thunderstorms and lightning will increase the risk of damage to external over-voltage protection areas.

5. The connection of MPPT controller

5.1 The components of PV system

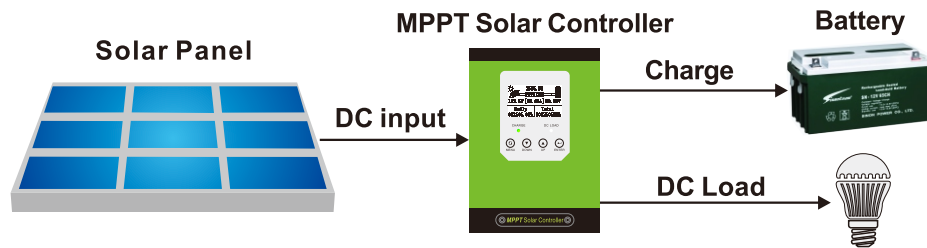

5.2 Wire connection

5.2.1 Wire steps

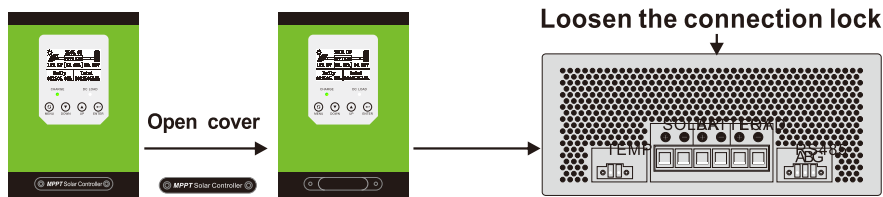

5.2.2 Battery connection



Warning: the short circuit of batteries positive and negative terminals and its wires may cause a risk of fire or explosion. Please be careful!

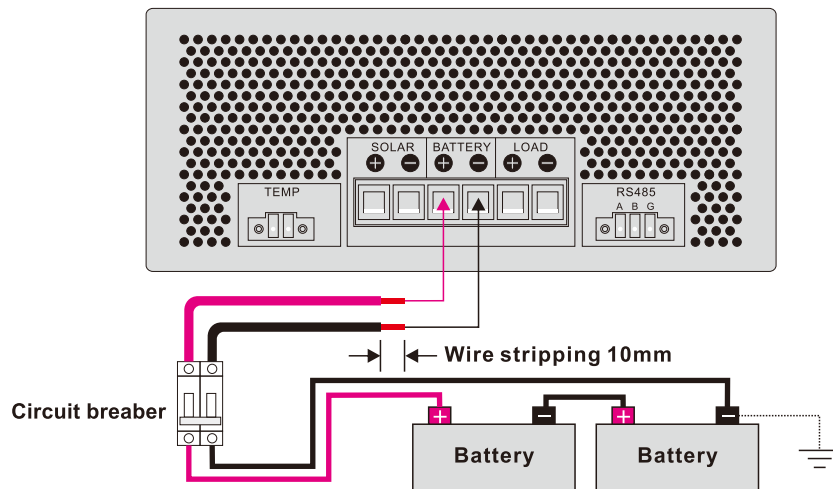

Notes: when you connect the batteries, it must be disconnected the circuit breaker.

6.4.11.3 Charge voltage setting

Under the operation parameter, press the DOWN key to select the charge voltage setting and press the ENTER key to enter the charge voltage setting. Press the UP key to move the cursor, press the DOWN key to enter the value, press the ENTER key to confirm the save, and press the MENU Key to return to the previous menu.

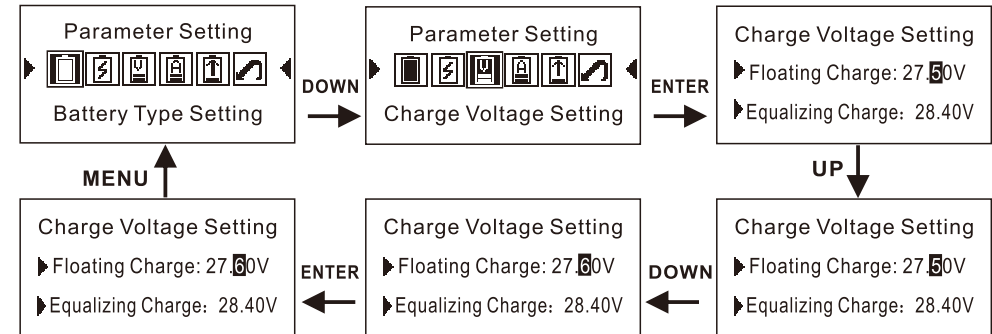

i Lithium battery series only have float (constant voltage) charging mode, and the equalizing charging mode is used by lead-acid battery series.

6.4.11.4 Charge current setting

Under the operation parameters interface, press the DOWN key to select the charge current setting and press the ENTER key to enter the charge current setting. Press the UP key to move the cursor, press the DOWN key to enter the value, press the ENTER key to confirm the save, and after hear the continuous tone and press the MENU key to return to the previous menu.

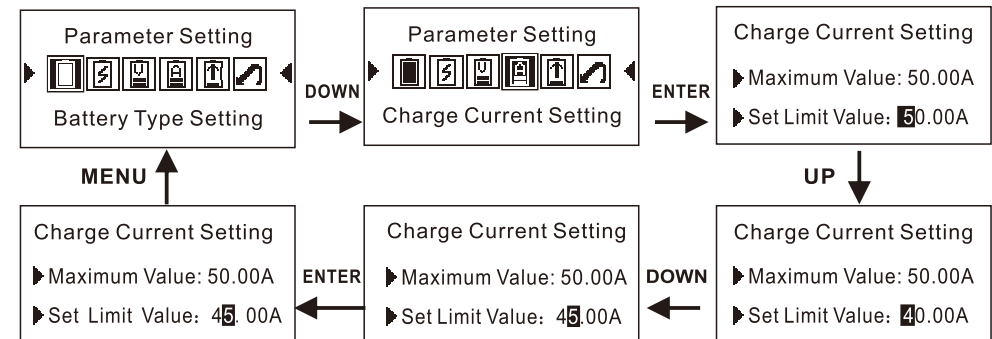

i The set value of charge current can not be greater than the current maximum value

6. MPPT operate instructions

6.4.11.1 Battery type setting

Under the operation parameters interface, press the ENTER key to enter the battery type setting, press the DOWN key to select the battery type (lead-acid battery, colloidal battery, liquid battery, lithium battery), and then press the ENTER key to confirm, after hear the continuous tone and press the MENU key to return to the previous menu.

i The factory default is lead-acid battery

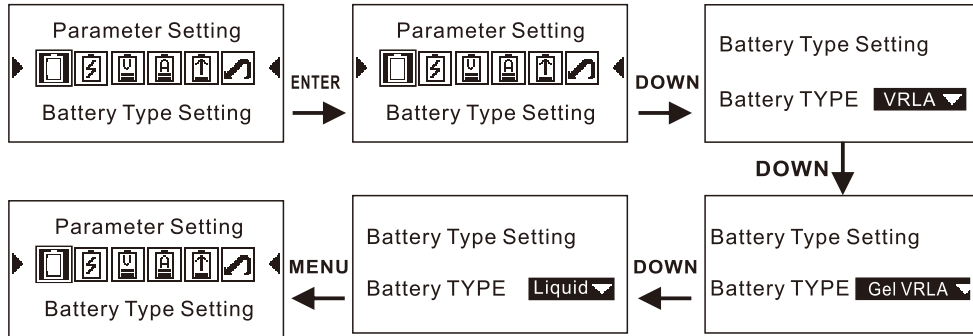

6.4.11.2 Battery rated voltage

Under the operation parameters interface, press the DOWN key to select the rated voltage setting and press the ENTER key to enter the rated voltage setting. Press the DOWN key to select the rated voltage level (auto identification, 12V, 24V, 36V, 48V). Press the ENTER key to confirm and after hear the continuous tone and press the MENU key to return to the previous menu.

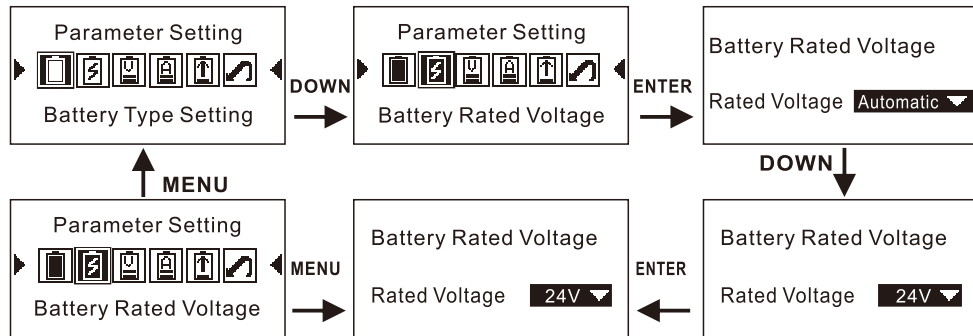

i The factory default is to automatically recognize the rated voltage grade. The automatic identification of rated voltage grade only identify lead-acid battery series. Lithium battery is not included in the automatic identification range. When the voltage grade is automatically recognized, the setting of charge voltage and the discharge lower limit voltage are not allowed. It must be manually set the voltage grade first, and then to set the charge voltage and discharge lower limit voltage.

5.2.3 DC load connection

Controller "DC LOAD" load side can be connected to the rated operating voltage and battery rated voltage of the same DC power equipment, the controller supplies the power at the battery voltage.

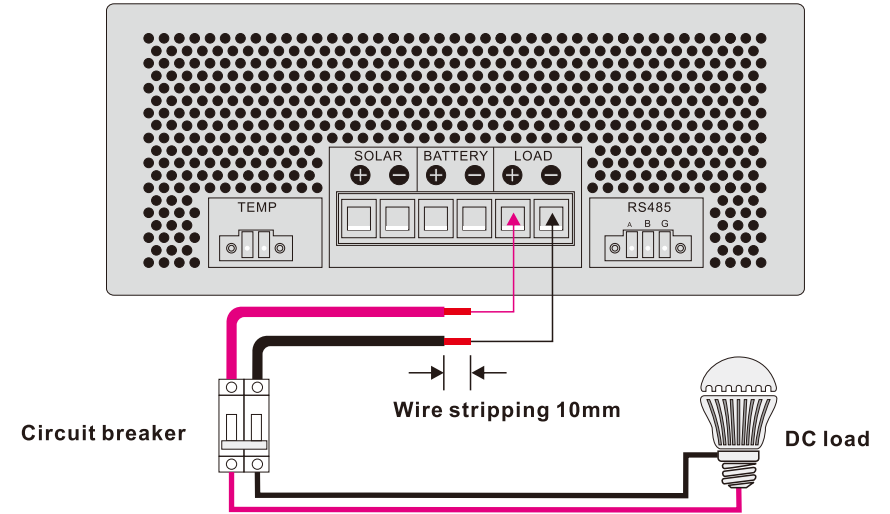

5.2.4 PV module connection

Warning: Risk of electric shock! The PV module may produce a high voltage and be careful to avoid electric shock when wiring.

The controller can be used for 12V, 24V, 48V off-grid solar modules, and can also use open-circuit voltage which does not exceed the specified maximum input voltage of the grid components. The solar component voltage in the system is not lower than the system voltage.

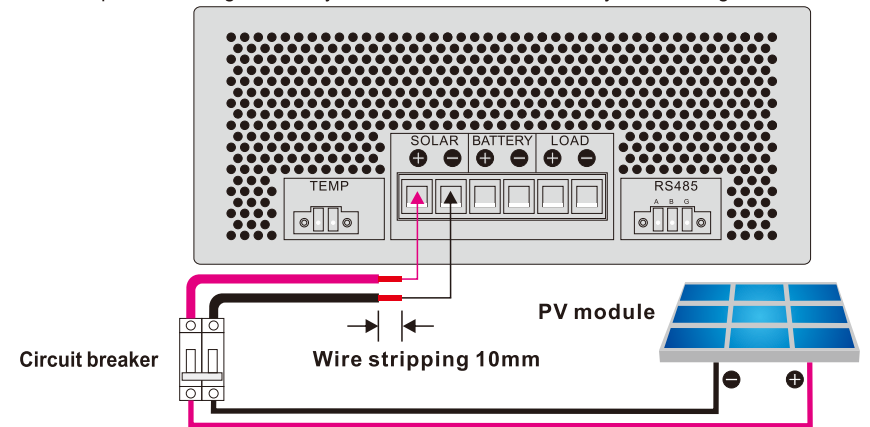

Notes: when you connect the PV module, it must be disconnected the circuit breaker.

5 . The connection of MPPT controller

The specifications of cable and miniature circuit breaker

Model	12/24/48V					48/96V		
	TYC-20IR	TYC-30IR	TYC-40IR	TYC-50IR	TYC-60IR	TYC-40A96	TYC-50A96	TYC-50A96
	TYC-20AL	TYC-30AL	TYC-40AL	TYC-50AL	TYC-60AL	TYC-40AL96	TYC-50AL96	TYC-50AL96
Cable (copper)	4MM ²	6MM ²	8MM ²	10MM ²	16MM ²	4MM ²	4MM ²	4MM ²
Circuit breaker	25A	32A	63A	63A	80A	63A	63A	80A

5.2.5 The temperature sensor and the MPPT controller connected to the PC

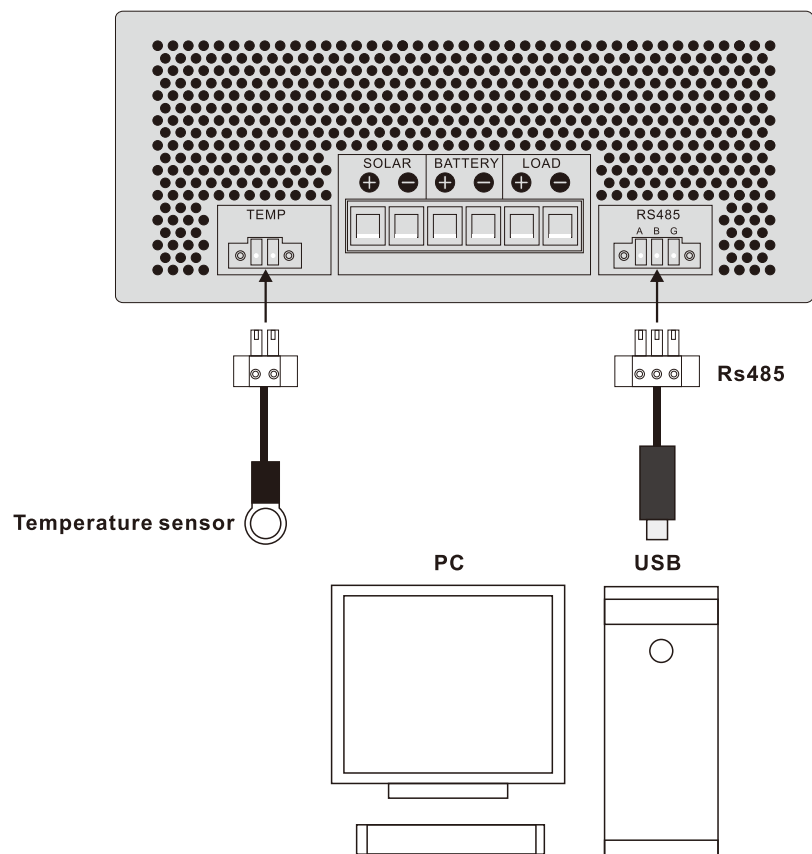

Rs485 communication line is optional

If necessary to install, it needs to be purchased separately. And accessories with detailed instructions for use and installation.

6.4.10 Communication setting

In the default main interface, press the MENU key to enter the main menu, press the DOWN key to select the communication setting, press the ENTER key to enter the communication settings, press the UP key to select the baud rate setting or the local address setting, press the DOWN key to set the baud rate and the local address value, press the ENTER key to confirm, after hear the continuous tone and press the MENU key to return to the previous menu and the main interface

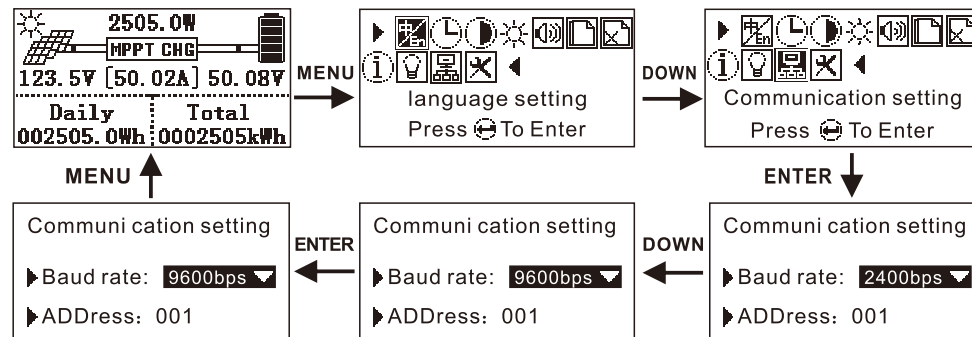

6.4.11 Operation parameter Setting



Note: The operation parameter setting must be conducted by qualified electrical engineering personnel, otherwise the mis-operation might cause the MPPT does not work or damage the battery.

In the default main interface, press the MENU button to enter the main menu, press the DOWN key to select the run parameter setting, press the ENTER key to enter the pass – word prompt interface, enter the password and press ENTER to enter the run parameter setting.

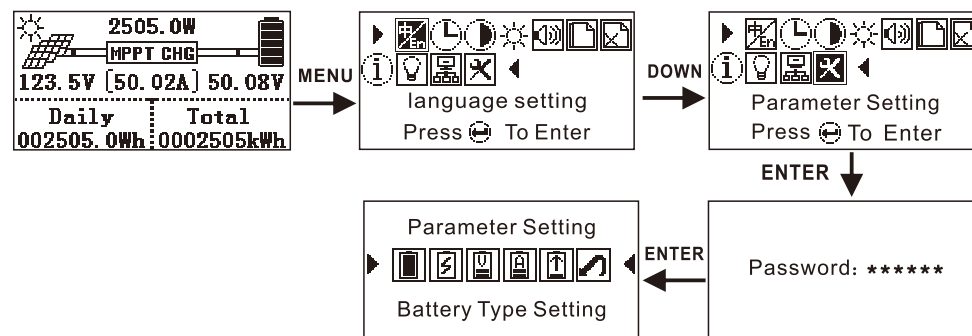

Note: Before setting the operating parameters, you must disconnect the PV module from the MPPT controller. Then in order set below parameter: 1. battery type setting, 2. the rated voltage setting, 3. the charging voltage setting, 4. the charging current setting, 5.the discharging lower limit setting. And then check the displayed parameter of system information whether it is consistent or not.

6. MPPT operate instructions

6.4.8 System information query

In the default main interface, press the MENU key to enter the main menu, press the DOWN key to select the system information, press the ENTER key to enter the system information, press the MENU key to return to the main interface.

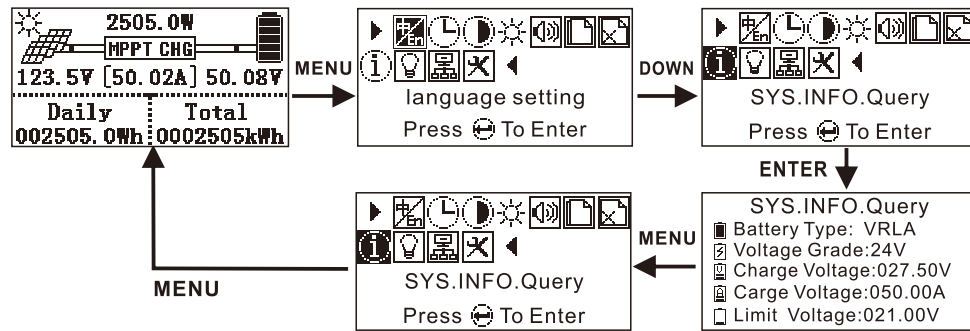

6.4.9 DC output setting

In the default main interface, press the MENU key to enter the main menu, press the DOWN key to select the DC output setting, press the ENTER key to enter the DC output setting, press the DOWN key to select OFF, AUTO, TIME CONTROL. When you select Off or Auto, press ENTER to confirm, and when you select TIME CONTROL, it needs select time period to turn on and off of the DC output. Press the DOWN key to select the time control and press the UP key to move the cursor. Press the DOWN key to enter the time value. Press the ENTER key to confirm, after hear the continuous tone and press the MENU key to return to the previous menu and the main interface.

Note: The turn off is directly turn off the DC output, automatic is opening the DC output after MPPT connect to the battery, except for the battery undervoltage, and time control is to open and close the DC output according to the time period setting.

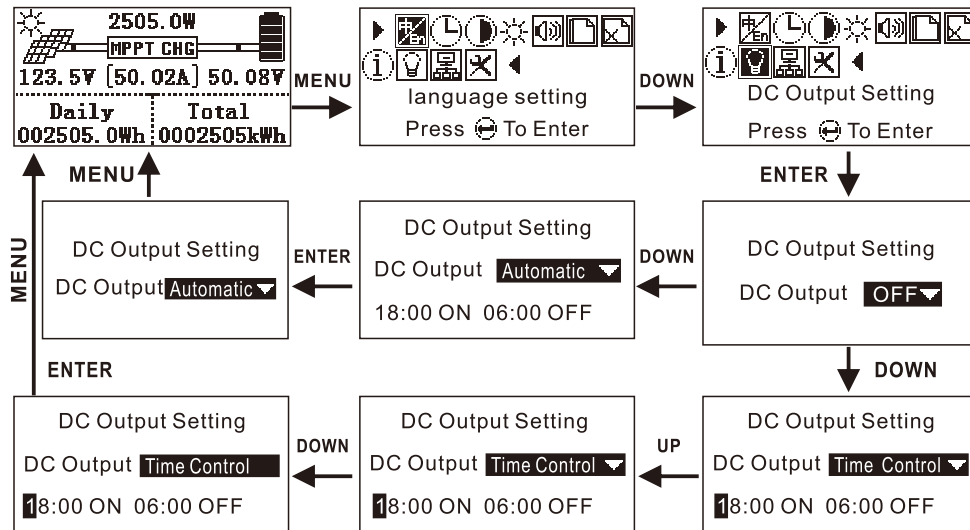

5.3 Power test run



Note: Before power test, please check all the DC wire positive and negative terminals are fully connected correctly.

Please follow below steps to operate:

1. Check the positive and negative terminals of wire must be full connected correctly, and measure that whether the open circuit voltage of the PV module is within the operating range of the controller.
2. Firstly, turn on the circuit breaker of the connection of controller and battery.
3. Secondly, turn on the circuit breaker of the connection of controller and solar panel.
4. Finally, the controller starts to enter the self-test mode; if the system conditions are correct, the controller automatically enter the work mode; if the system conditions are not correct, the controller will be a fault prompt, refer to the chapter to solve the fault.
5. Battery type, the controller factory default is lead-acid battery, please refer to the battery type settings.

6.MPPT operate instructions

6.1 Panel component description

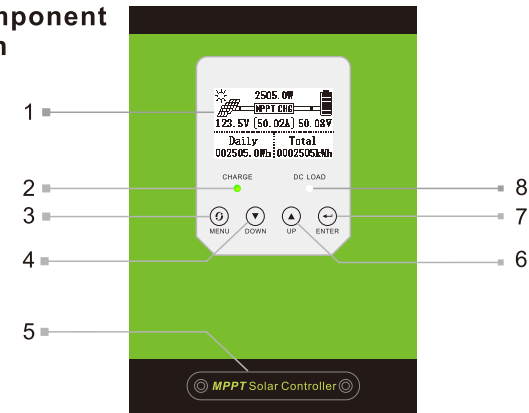

No.	Name	No.	Name
1	LCD display	5	Wire connection cover
2	Charging status indicator	6	Up page button
3	Menu button	7	Enter
4	Down page button	8	DC output indicator

Item	Status	Description
Charging indicator	Quick flashing	Maximum power tracking charging
	Slow flashing	Float mode charge
	lighting off	Stop charging
DC output indicator	Light on	Normal output
	Light flashing	The battery is under-voltage
	Light off	Close output

6. MPPToperate instructions

6.3.LCD display description

6.3.1 Main interface description

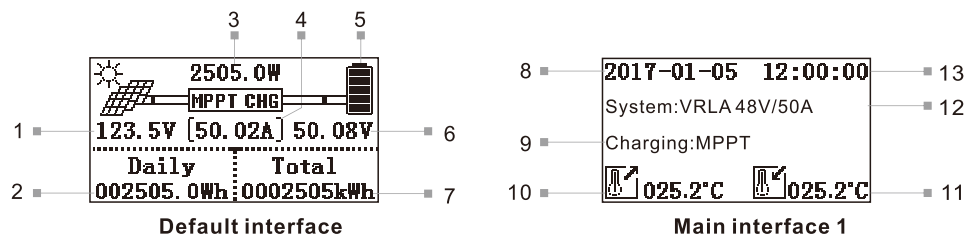

No.	Description	No.	Description
1	PV module voltage	8	Date
2	Daily production (Charging capacity)	9	Charging status: the maximum power tracking, float charging or stop charging.
3	Charging power	10	External temperature
4	Charging current	11	Internal temperature
5	Battery capacity instruction	12	Battery type/the voltage and current grade of system
6	Battery voltage	13	Real time
7	Total production (Charging capacity)		

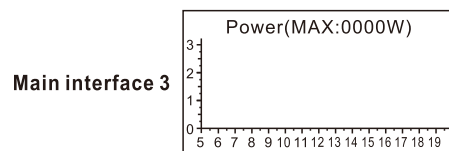
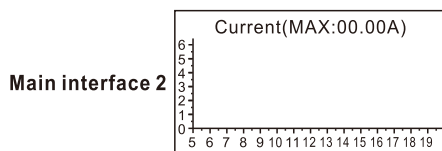

Name	Current curve (MAX:00.00A)	Name	Powe curve (MAX:0000W)
X	Time. (5: 00-20: 00)	X	Time. (5: 00-20: 00)
Y	Current (Proportion: 1: 10)	Y	Power (Proportion: 1: 1000)
MAX:00.00A (Record the maximum charging current a day)		MAX:0000W(Record the maximum charge power a day)	

6.3.2 Check the main interface

Please press DOWN OR UP to have a check under the default main interface.

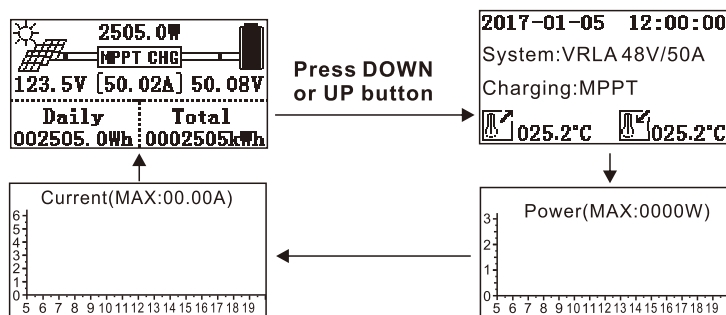

Record query

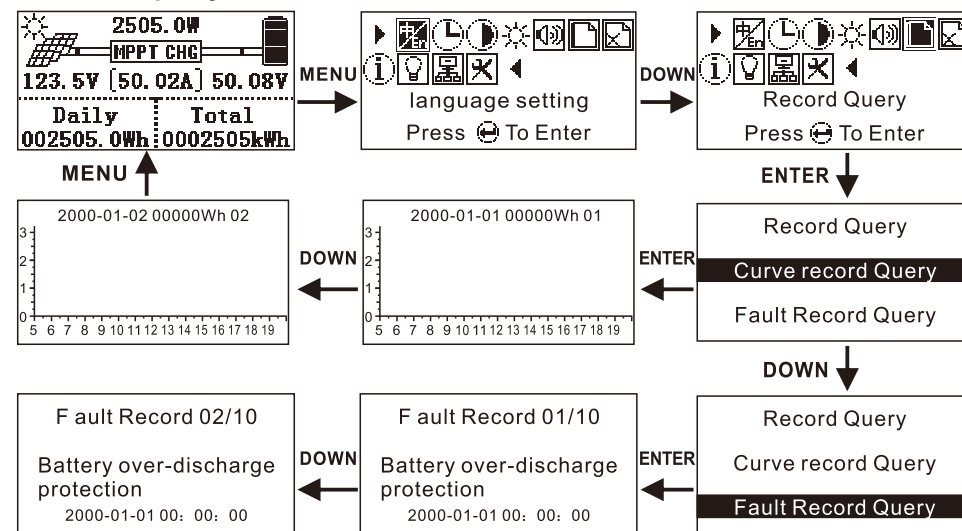

6.4.7 Delete Record

In the default main interface, press the MENU key to enter the main menu, press the DOWN key to select the delete record, press the ENTER key to enter the delete record, press the UP key to move the cursor, press the DOWN key to select whether to delete, select and press ENTER to confirm the delete. Press the MENU key to return to the previous menu and the main interface.

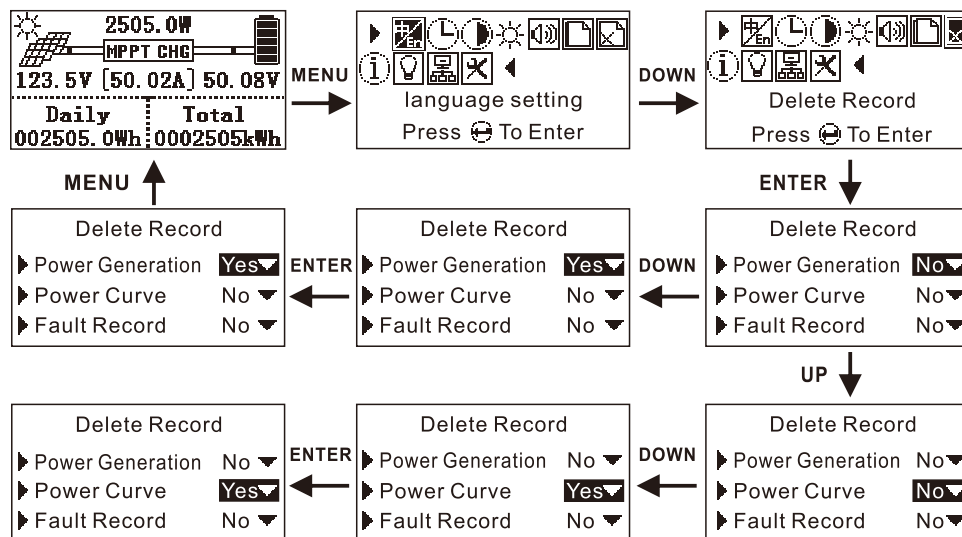

6. MPPT operate instructions

Contrast Adjustment

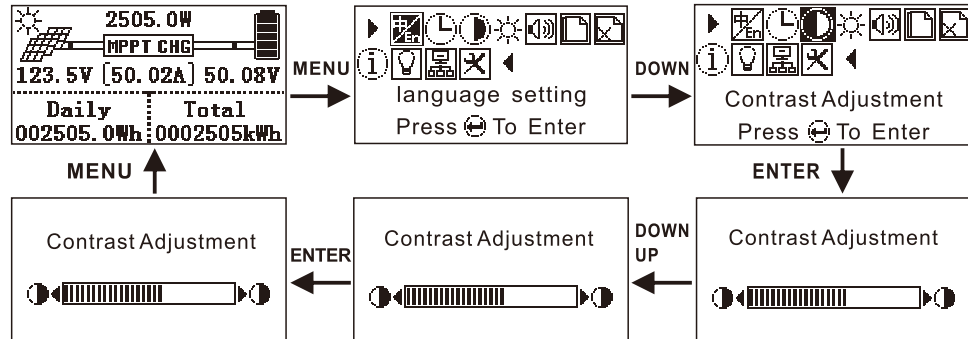

6.4.4 Brightness Adjustment

The operation of the brightness setting is the same as the contrast setting

6.4.5 Sound setting

In the default main interface, press the MENU key to enter the main menu, press the DOWN key to select the sound setting, press the ENTER key to enter the sound setting, press the DOWN key to select the key to turn on or off, press the UP key to move the cursor to select the alarm sound on or off, press ENTER key to confirm, after hear the continuous tone press MENU to return to the main interface.

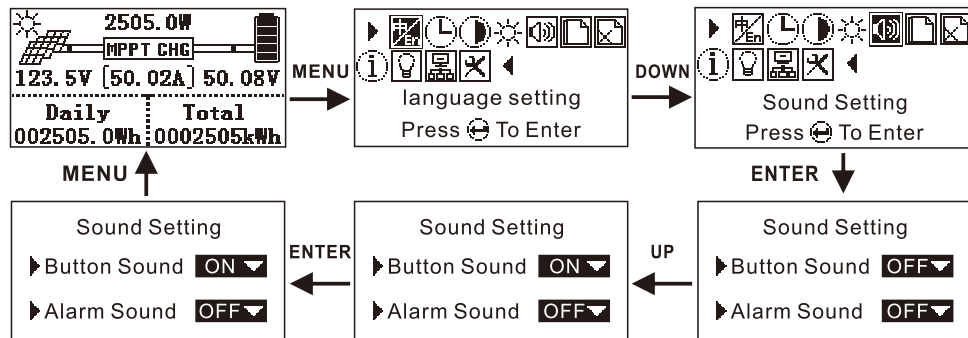

6.4.6 Record query

In the default main interface, press the ENTER key to enter the main menu, press the DOWN key to select the record query, press the ENTER key to enter the record query, press the DOWN key or UP key to select the curve record query or fault record query, press the ENTER key to enter the curve record query or Fault record query, press the DOWN or UP key to enter the record, a total of 10 records. Press MENU to return to the previous menu and main interface.

6.3.4 Main interface

Press the MENU button in the default main interface to enter the main menu and press DOWN or UP to view the submenu.

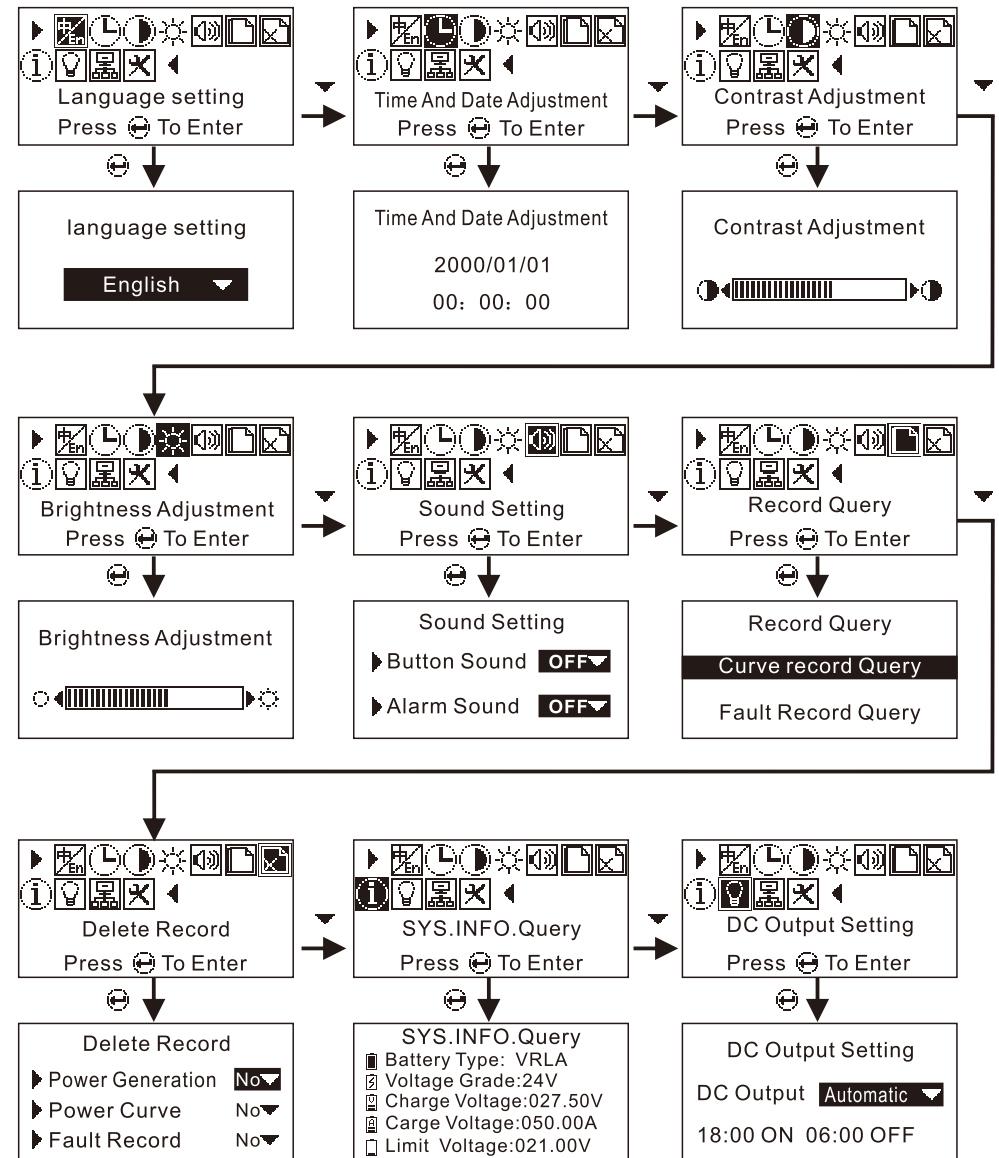

6. MPPToperate instructions

Main Menu

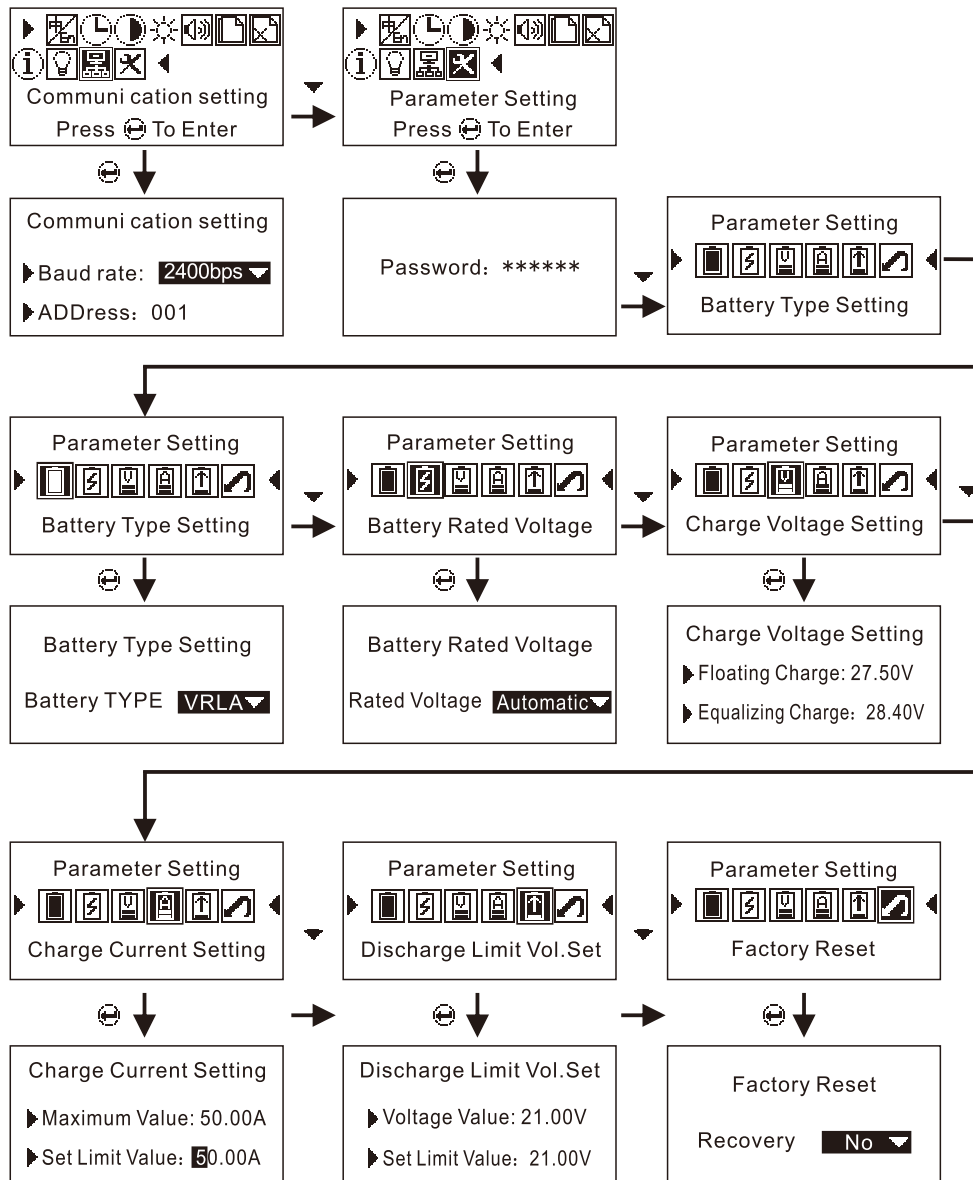

6.4 Parameter setting

6.4.1 Language setting

In the default main interface, press the MENU key to enter the main menu, press the ENTER key to enter the language settings, press the DOWN key to select the language and press the ENTER key to confirm, hear the continuous tone and press MENU to return to the main interface.

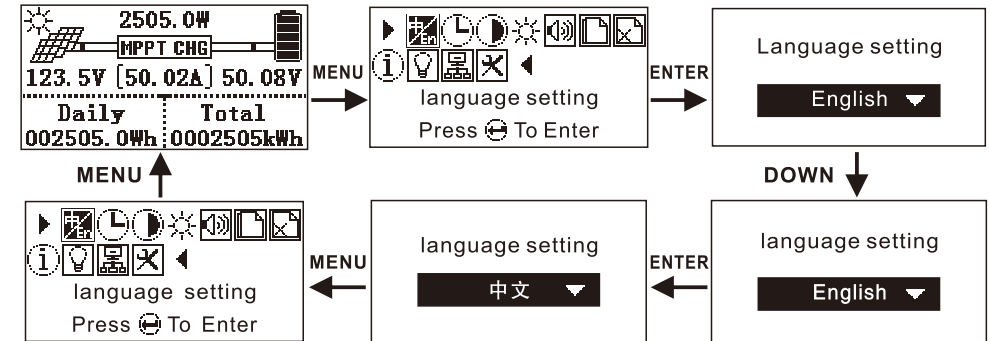

6.4.2 Time and date adjustment

In the default main interface press the ENTER key to enter the main menu, press the DOWN key to select the time setting, press the ENTER key to enter the time setting, press the UP key to move the cursor, press the DOWN key to modify the value, after modified value and press the ENTER key to confirm, hear the continuous tone and press MENU to return to the main interface.

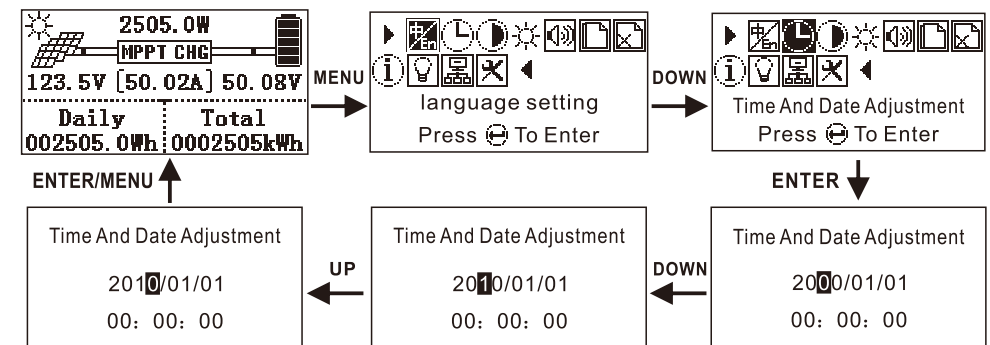

6.4.3 Contrast adjustment

In the default main interface, press the MENU key to enter the main menu, press the DOWN key to select the contrast setting, press the ENTER key to enter the contrast setting, press the DOWN key to decrease the contrast, press the UP key to increase the contrast, press the ENTER key to confirm, after hear the continuous tone and press the MENU button to return to the upper menu and the main interface.