

YEEDA PULAITE





Wenzhou Pulaite Technology Co., Ltd. is located in Wenzhou, the most dynamic and pioneering city in China. We are mainly engaged in the R&D, manufacturing, sales and service of warning & lighting products such as vehicle tower lighting equipment, warning equipment, traffic display , portable working lights and other lighting products for fire trucks, police, ambulance, armor vehicle or other special fitting car factories. Our products had exported to Europe, America, Middle East, Southeast Asia and other countries. Wenzhou Pulaite was invested by Yeeda electric (Suzhou) Co., Ltd., and jointly established with a 15-year professional technical team. We inspires to become the most craftsmanship enterprise at this special lighting industry, promotes and leads the development of this industry. Combines industry and finance, in the next 3 years, we mostly focus on technology research and development to achieve tenfold growth, thus becoming a democratic spirit Technology-based IPO company.



Content

目录

Vehicle mounted mast light	4-21
Telescopic mast	22-25
Collapsible Mast & Antenna PTZ	26-27
Fittings	28-29
Smart system	30
Portable lighting products	31-36
Search lights	37
Warning Lights	38-43
Sirens & speakers	44-45
Traffic display screen	46-47
Acoustic device	48-49
Certificate	50-51





Vehicle mounted mast light

1.2 meter height series

1.2 meter high lighting equipment, suitable for vehicles such as communication command vehicles, lighting vehicles, rescue vehicles, fire fighting vehicles, and other medium-sized special vehicles.

It has function of up and down, rising from horizontal to vertical 90 degree, the rotating head can be 380° vertical rotating and 330° horizontal rotating to complete positioning lighting.

A camera mounting bracket can be installed on the top of rotating head or mount between the two lights. Camera rotates horizontally at 380 ° and vertical at 180 °.

The lights adopts LED solid-state lighting or metal halogen as light source, power can be choose from 90W to 1000W.

Our controller has LCD screen to show product status and faulty, such as battery power, working voltage, lights on or off, etc.

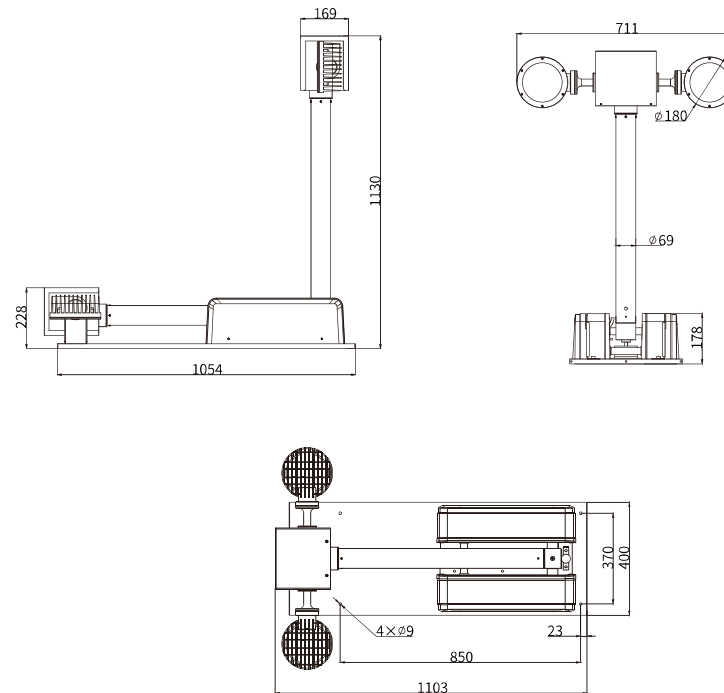



5



Specifications:

--2 lamps details

Models	System Rated voltage	Lamps Rated voltage	Light source	Lamp type	Lamp power	Light lumen	Net.Weight	Pitch NO.	Horizontal rotary	Vertical Rotary
CHL122120	DC12V/24V	DC12V/24V/AC220V	LED	Flood/Spot	120W*2	25200lm	38kg	1	380°	330°
CHL122200	DC12V/24V	DC12V/24V/AC220V	LED	Flood/Spot	200W*2	42000lm	40kg			
CHL122250	DC12V/24V	AC220V	LED	Flood/Spot	250W*2	52500lm	42kg			
CHL122400	DC12V/24V	AC220V	LED	Flood/Spot	400W*2	84000lm	42kg			
CHX122600	DC12V/24V	AC220V	LED	Flood/Spot	600W*2	138000lm	40kg			
CHX122700	DC12V/24V	AC220V	LED	Flood/Spot	700W*2	161000lm	40kg			
CFA122150	DC12V/24V	DC12V/24V/AC220V	Metal halogen	Flood	150W*2	22000lm	40kg			
CHG122250	DC12V/24V	AC220V	Metal halogen	Flood/Spot	250W*2	40000lm	40kg			
CHG122400	DC12V/24V	AC220V	Metal halogen	Flood/Spot	400W*2	72000lm	40kg			
CHG122600	DC12V/24V	AC220V	Metal halogen	Flood/Spot	600W*2	90000lm	40kg			
CHG1221000	DC12V/24V	AC220V	Metal halogen	Spot	1000W*2	110000lm	40kg			

--4 lamps details

Models	System Rated voltage	Lamps Rated voltage	Light source	Lamp type	Lamp power	Light lumen	Net.Weight	Pitch NO.	Horizontal rotary	Vertical Rotary
CHL124120	DC12V/24V	DC12V/24V/AC220V	LED	Flood/Spot	120W*4	50400lm	46kg	1	380°	330°
CHL124200	DC12V/24V	DC12V/24V/AC220V	LED	Flood/Spot	200W*4	84000lm	48kg			
CHL124250	DC12V/24V	AC220V	LED	Flood/Spot	250W*4	105000lm	50kg			
CHL124400	DC12V/24V	AC220V	LED	Flood/Spot	400W*4	168000lm	50kg			
CHX124600	DC12V/24V	AC220V	LED	Flood/Spot	600W*4	276000lm	48kg			
CHX124700	DC12V/24V	AC220V	LED	Flood/Spot	700W*4	322000lm	48kg			
CFA124150	DC12V/24V	DC12V/24V/AC220V	Metal halogen	Flood	150W*4	44000lm	48kg			
CHG124250	DC12V/24V	AC220V	Metal halogen	Flood/Spot	250W*4	80000lm	48kg			
CHG124400	DC12V/24V	AC220V	Metal halogen	Flood/Spot	400W*4	144000lm	48kg			
CHG124600	DC12V/24V	AC220V	Metal halogen	Flood/Spot	600W*4	180000lm	48kg			
CHG1241000	DC12V/24V	AC220V	Metal halogen	Spot	1000W*4	220000lm	48kg			

Vehicle mounted mast light

1.8 meter height series

1.8 meter high lighting equipment, suitable for vehicles such as communication command vehicles, lighting vehicles, rescue vehicles, fire fighting vehicles, and other medium-sized special vehicles.

It has function of up and down, rising from horizontal to vertical 90 degree, the rotating head can be 380° horizontal rotating and 330° vertical rotating to complete positioning lighting.

A camera mounting bracket can be installed on the top of rotating head or mount between the two lights. Camera rotates horizontally at 380 ° and vertical at 180 °.

The lights adopts LED solid-state lighting or metal halogen as light source, power can be choose from 90W to 1000W.

Our controller has LCD screen to show product status and faulty, such as battery power, working voltage, lights on or off, etc.

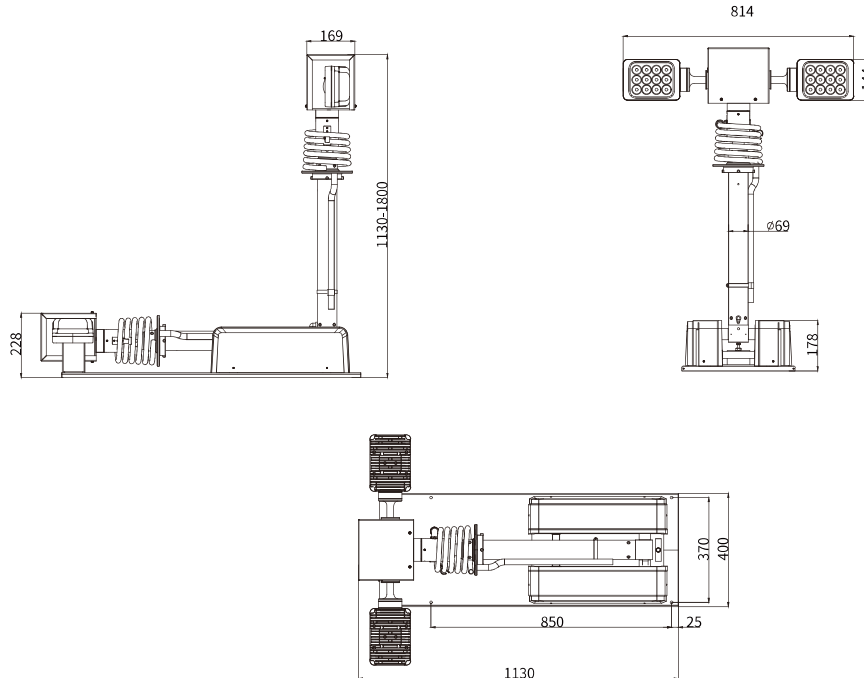

5



Specifications:

--2 lamps details

Models	System Rated voltage	Lamps Rated voltage	Light source	Lamp type	Lamp power	Light lumen	Net.Weight	Pitch NO.	Horizontal rotary	Vertical Rotary
★ CHL182120	DC12V/24V	DC12V/24V/AC220V	LED	Flood/Spot	120W*2	25200lm	48kg	3	380°	330°
CHL182200	DC12V/24V	DC12V/24V/AC220V	LED	Flood/Spot	200W*2	42000lm	50kg			
CHL182250	DC12V/24V	AC220V	LED	Flood/Spot	250W*2	52500lm	52kg			
CHL182400	DC12V/24V	AC220V	LED	Flood/Spot	400W*2	84000lm	52kg			
CHX182600	DC12V/24V	AC220V	LED	Flood/Spot	600W*2	138000lm	50kg			
CHX182700	DC12V/24V	AC220V	LED	Flood/Spot	700W*2	161000lm	50kg			
CFA182150	DC12V/24V	DC12V/24V/AC220V	Metal halogen	Flood	150W*2	22000lm	50kg			
CHG182250	DC12V/24V	AC220V	Metal halogen	Flood/Spot	250W*2	40000lm	50kg			
CHG182400	DC12V/24V	AC220V	Metal halogen	Flood/Spot	400W*2	72000lm	50kg			
CHG182600	DC12V/24V	AC220V	Metal halogen	Flood/Spot	600W*2	90000lm	50kg			
CHG1821000	DC12V/24V	AC220V	Metal halogen	Spot	1000W*2	110000lm	50kg			

--4 lamps details

Models	System Rated voltage	Lamps Rated voltage	Light source	Lamp type	Lamp power	Light lumen	Net.Weight	Pitch NO.	Horizontal rotary	Vertical Rotary
CHL184120	DC12V/24V	DC12V/24V/AC220V	LED	Flood/Spot	120W*4	50400lm	56kg	3	380°	330°
CHL184200	DC12V/24V	DC12V/24V/AC220V	LED	Flood/Spot	200W*4	84000lm	58kg			
CHL184250	DC12V/24V	AC220V	LED	Flood/Spot	250W*4	105000lm	60kg			
CHL184400	DC12V/24V	AC220V	LED	Flood/Spot	400W*4	168000lm	60kg			
CHX184600	DC12V/24V	AC220V	LED	Flood/Spot	600W*4	276000lm	58kg			
CHX184700	DC12V/24V	AC220V	LED	Flood/Spot	700W*4	322000lm	58kg			
CFA184150	DC12V/24V	DC12V/24V/AC220V	Metal halogen	Flood	150W*4	44000lm	58kg			
CHG184250	DC12V/24V	AC220V	Metal halogen	Flood/Spot	250W*4	80000lm	58kg			
CHG184400	DC12V/24V	AC220V	Metal halogen	Flood/Spot	400W*4	144000lm	58kg			
CHG184600	DC12V/24V	AC220V	Metal halogen	Flood/Spot	600W*4	180000lm	58kg			
CHG1841000	DC12V/24V	AC220V	Metal halogen	Spot	1000W*4	220000lm	58kg			

Vehicle mounted mast light

2.5 meter height series

2.5 meter high lighting equipment, suitable for vehicles such as communication command vehicles, lighting vehicles, rescue vehicles, fire fighting vehicles, and other medium-sized special vehicles.

It has function of up and down, rising from horizontal to vertical 90 degree, the rotating head can be 380° horizontal rotating and 330° vertical rotating to complete positioning lighting.

A camera mounting bracket can be installed on the top of rotating head or mount between the two lights. Camera rotates horizontally at 380 ° and vertical at 180 °.

The lights adopts LED solid-state lighting or metal halogen as light source, power can be choose from 90W to 1000W.

Our controller has LCD screen to show product status and faulty, such as battery power, working voltage, lights on or off, etc.

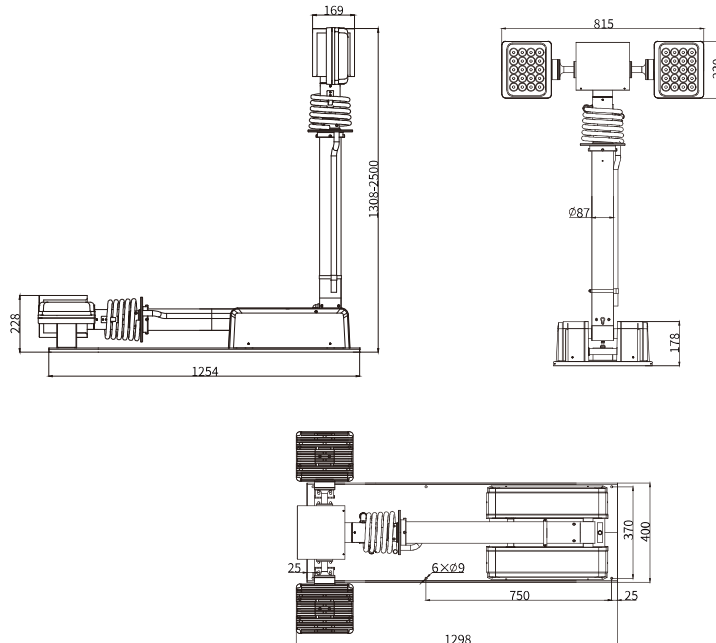
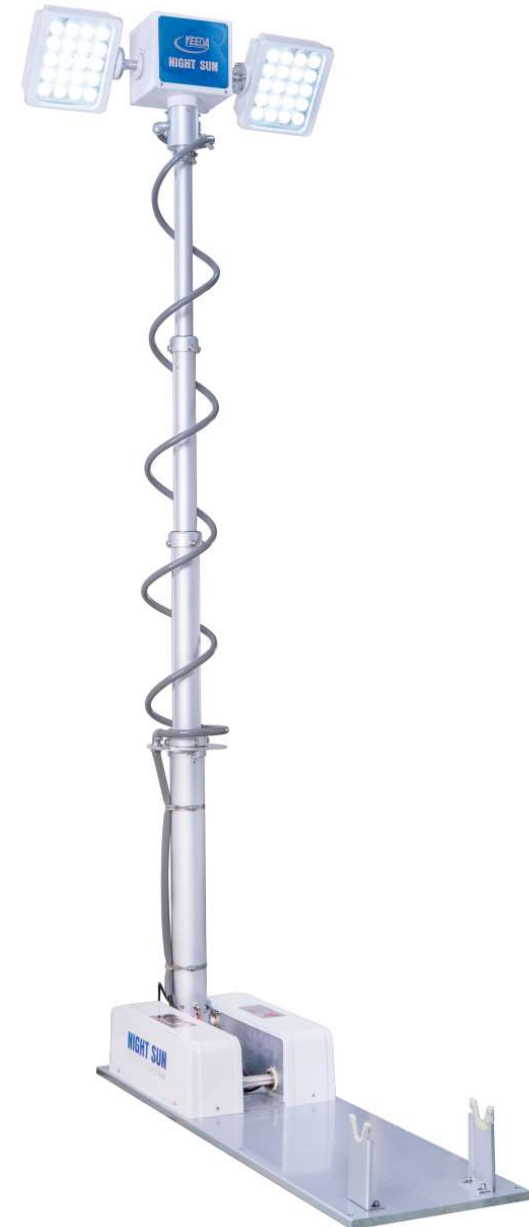

5



Specifications:

--2 lamps details

Models	System Rated voltage	Lamps Rated voltage	Light source	Lamp type	Lamp power	Light lumen	Net.Weight	Pitch NO.	Horizontal rotary	Vertical Rotary
CHL252120	DC12V/24V	DC12V/24V/AC220V	LED	Flood/Spot	120W*2	25200lm	53kg	4	380°	330°
★ CHL252200	DC12V/24V	DC12V/24V/AC220V	LED	Flood/Spot	200W*2	42000lm	55kg			
CHL252250	DC12V/24V	AC220V	LED	Flood/Spot	250W*2	52500lm	57kg			
CHL252400	DC12V/24V	AC220V	LED	Flood/Spot	400W*2	84000lm	57kg			
CHX252600	DC12V/24V	AC220V	LED	Flood/Spot	600W*2	138000lm	55kg			
CHX252700	DC12V/24V	AC220V	LED	Flood/Spot	700W*2	161000lm	55kg			
CFA252150	DC12V/24V	DC12V/24V/AC220V	Metal halogen	Flood	150W*2	22000lm	55kg			
CHG252250	DC12V/24V	AC220V	Metal halogen	Flood/Spot	250W*2	40000lm	55kg			
CHG252400	DC12V/24V	AC220V	Metal halogen	Flood/Spot	400W*2	72000lm	55kg			
CHG252600	DC12V/24V	AC220V	Metal halogen	Flood/Spot	600W*2	90000lm	55kg			
CHG2521000	DC12V/24V	AC220V	Metal halogen	Spot	1000W*2	110000lm	55kg			

--4 lamps details

Models	System Rated voltage	Lamps Rated voltage	Light source	Lamp type	Lamp power	Light lumen	Net.Weight	Pitch NO.	Horizontal rotary	Vertical Rotary
CHL254120	DC12V/24V	DC12V/24V/AC220V	LED	Flood/Spot	120W*4	50400lm	61kg	4	380°	330°
CHL254200	DC12V/24V	DC12V/24V/AC220V	LED	Flood/Spot	200W*4	84000lm	63kg			
CHL254250	DC12V/24V	AC220V	LED	Flood/Spot	250W*4	105000lm	65kg			
CHL254400	DC12V/24V	AC220V	LED	Flood/Spot	400W*4	168000lm	65kg			
CHX254600	DC12V/24V	AC220V	LED	Flood/Spot	600W*4	276000lm	63kg			
CHX254700	DC12V/24V	AC220V	LED	Flood/Spot	700W*4	322000lm	63kg			
CFA254150	DC12V/24V	DC12V/24V/AC220V	Metal halogen	Flood	150W*4	44000lm	63kg			
CHG254250	DC12V/24V	AC220V	Metal halogen	Flood/Spot	250W*4	80000lm	63kg			
CHG254400	DC12V/24V	AC220V	Metal halogen	Flood/Spot	400W*4	144000lm	63kg			
CHG254600	DC12V/24V	AC220V	Metal halogen	Flood/Spot	600W*4	180000lm	63kg			
CHG2541000	DC12V/24V	AC220V	Metal halogen	Spot	1000W*4	220000lm	63kg			

Vehicle mounted mast light

3.5 meter height series

3.5 meter high lighting equipment, suitable for vehicles such as communication command vehicles, lighting vehicles, rescue vehicles, fire fighting vehicles, and other large-sized special vehicles.

It has function of up and down, rising from horizontal to vertical 90 degree, the rotating head can be 380° horizontal rotating and 330° vertical rotating to complete positioning lighting.

A camera mounting bracket can be installed on the top of rotating head or mount between the two lights. Camera rotates horizontally at 380 ° and vertical at 180 °.

The lights adopts LED solid-state lighting or metal halogen as light source, power can be choose from 90W to 1000W.

Our controller has LCD screen to show product status and faulty, such as battery power, working voltage, lights on or off, etc.

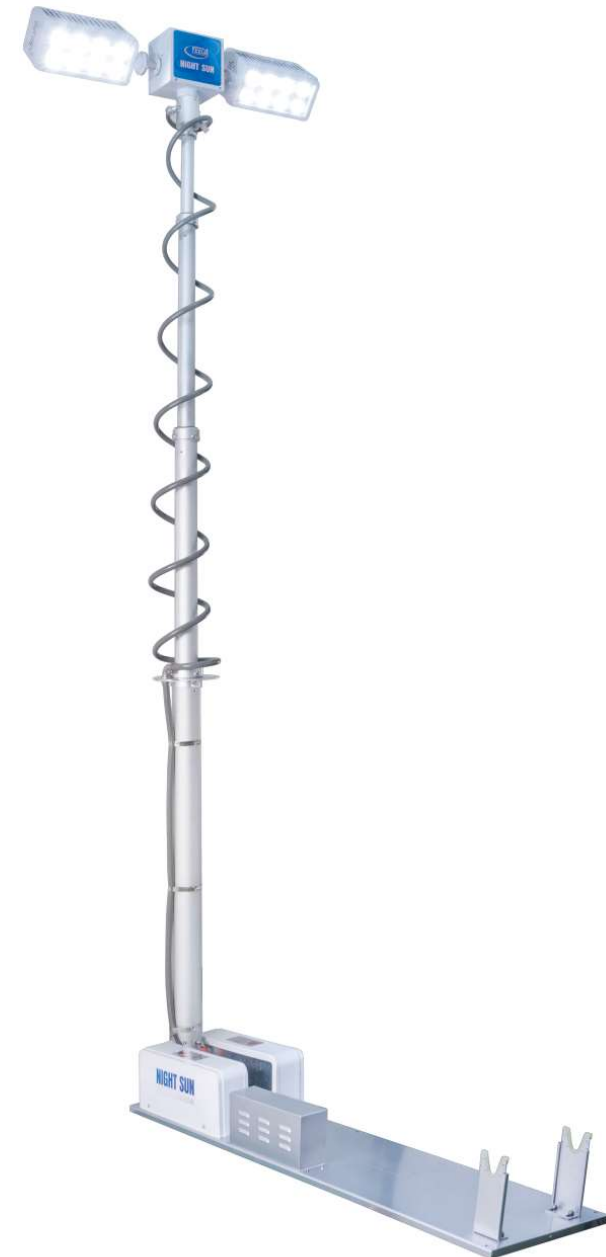
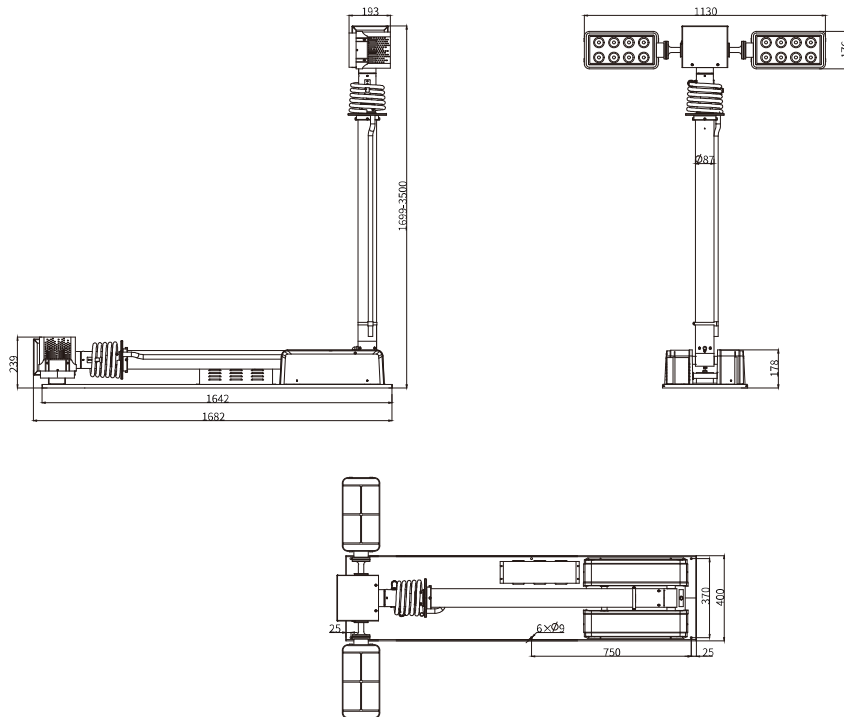

5



Specifications:

--2 lamps details

Models	System Rated voltage	Lamps Rated voltage	Light source	Lamp type	Lamp power	Light lumen	Net.Weight	Pitch NO.	Horizontal rotary	Vertical Rotary
CHL352120	DC12V/24V	DC12V/24V/AC220V	LED	Flood/Spot	120W*2	25200lm	63kg	4	380°	330°
CHL352200	DC12V/24V	DC12V/24V/AC220V	LED	Flood/Spot	200W*2	42000lm	65kg			
CHL352250	DC12V/24V	AC220V	LED	Flood/Spot	250W*2	52500lm	67kg			
★CHL352400	DC12V/24V	AC220V	LED	Flood/Spot	400W*2	84000lm	67kg			
CHX352600	DC12V/24V	AC220V	LED	Flood/Spot	600W*2	138000lm	65kg			
CHX352700	DC12V/24V	AC220V	LED	Flood/Spot	700W*2	161000lm	65kg			
CFA352150	DC12V/24V	DC12V/24V/AC220V	Metal halogen	Flood	150W*2	22000lm	65kg			
CHG352250	DC12V/24V	AC220V	Metal halogen	Flood/Spot	250W*2	40000lm	65kg			
CHG352400	DC12V/24V	AC220V	Metal halogen	Flood/Spot	400W*2	72000lm	65kg			
CHG352600	DC12V/24V	AC220V	Metal halogen	Flood/Spot	600W*2	90000lm	65kg			
CHG3521000	DC12V/24V	AC220V	Metal halogen	Spot	1000W*2	110000lm	65kg			

--4 lamps details

Models	System Rated voltage	Lamps Rated voltage	Light source	Lamp type	Lamp power	Light lumen	Net.Weight	Pitch NO.	Horizontal rotary	Vertical Rotary
CHL354120	DC12V/24V	DC12V/24V/AC220V	LED	Flood/Spot	120W*4	50400lm	71kg	4	380°	330°
CHL354200	DC12V/24V	DC12V/24V/AC220V	LED	Flood/Spot	200W*4	84000lm	73kg			
CHL354250	DC12V/24V	AC220V	LED	Flood/Spot	250W*4	105000lm	75kg			
CHL354400	DC12V/24V	AC220V	LED	Flood/Spot	400W*4	168000lm	75kg			
CHX354600	DC12V/24V	AC220V	LED	Flood/Spot	600W*4	276000lm	73kg			
CHX354700	DC12V/24V	AC220V	LED	Flood/Spot	700W*4	322000lm	73kg			
CFA354150	DC12V/24V	DC12V/24V/AC220V	Metal halogen	Flood	150W*4	44000lm	73kg			
CHG354250	DC12V/24V	AC220V	Metal halogen	Flood/Spot	250W*4	80000lm	73kg			
CHG354400	DC12V/24V	AC220V	Metal halogen	Flood/Spot	400W*4	144000lm	73kg			
CHG354600	DC12V/24V	AC220V	Metal halogen	Flood/Spot	600W*4	180000lm	73kg			
CHG3541000	DC12V/24V	AC220V	Metal halogen	Spot	1000W*4	220000lm	73kg			

Vehicle mounted mast light

4.2/4.5 meter height series

4.2 meter high lighting equipment, suitable for vehicles such as communication command vehicles, lighting vehicles, rescue vehicles, fire fighting vehicles, and other large-sized special vehicles.

It has function of up and down, rising from horizontal to vertical 90 degree, the rotating head can be 380° horizontal rotating and 330° vertical rotating to complete positioning lighting.

A camera mounting bracket can be installed on the top of rotating head or mount between the two lights. Camera rotates horizontally at 380 ° and vertical at 180 °.

The lights adopts LED solid-state lighting or metal halogen as light source, power can be choose from 90W to 1000W.

Our controller has LCD screen to show product status and faulty, such as battery power, working voltage, lights on or off, etc.

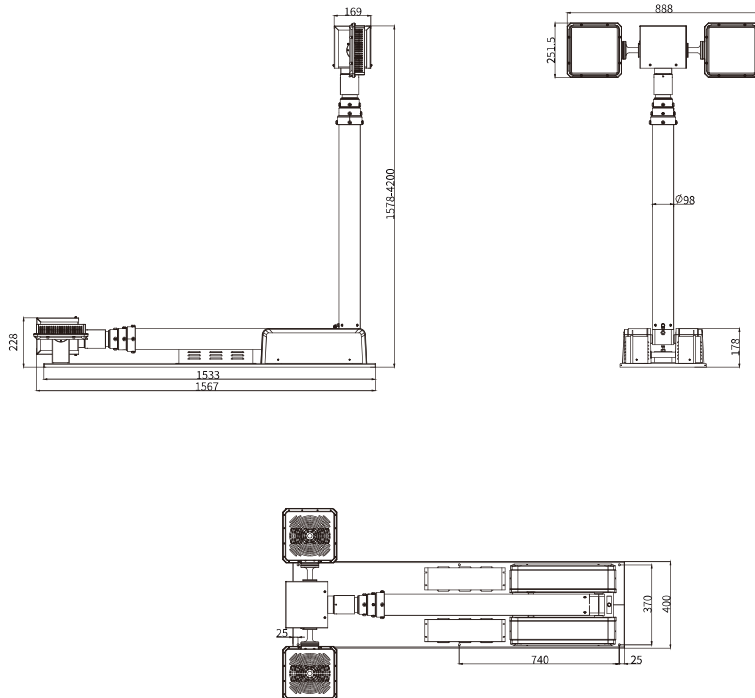

Specifications:

--2 lamps details

Models	System Rated voltage	Lamps Rated voltage	Light source	Lamp type	Lamp power	Light lumen	Net.Weight	Pitch NO.	Horizontal rotary	Vertical Rotary
CHL422120	DC12V/24V	DC12V/24V/AC220V	LED	Flood/Spot	120W*2	25200lm	63kg	5	380°	330°
CHL422200	DC12V/24V	DC12V/24V/AC220V	LED	Flood/Spot	200W*2	42000lm	65kg			
CHL422250	DC12V/24V	AC220V	LED	Flood/Spot	250W*2	52500lm	67kg			
CHL422400	DC12V/24V	AC220V	LED	Flood/Spot	400W*2	84000lm	67kg			
★ CHX422600	DC12V/24V	AC220V	LED	Flood/Spot	600W*2	138000lm	65kg			
CHX422700	DC12V/24V	AC220V	LED	Flood/Spot	700W*2	161000lm	65kg			
CFA422150	DC12V/24V	DC12V/24V/AC220V	Metal halogen	Flood	150W*2	22000lm	65kg			
CHG422250	DC12V/24V	AC220V	Metal halogen	Flood/Spot	250W*2	40000lm	65kg			
CHG422400	DC12V/24V	AC220V	Metal halogen	Flood/Spot	400W*2	72000lm	65kg			
CHG422600	DC12V/24V	AC220V	Metal halogen	Flood/Spot	600W*2	90000lm	65kg			
CHG4221000	DC12V/24V	AC220V	Metal halogen	Spot	1000W*2	110000lm	65kg			

--4 lamps details

Models	System Rated voltage	Lamps Rated voltage	Light source	Lamp type	Lamp power	Light lumen	Net.Weight	Pitch NO.	Horizontal rotary	Vertical Rotary
CHL424120	DC12V/24V	DC12V/24V/AC220V	LED	Flood/Spot	120W*4	50400lm	71kg	5	380°	330°
CHL424200	DC12V/24V	DC12V/24V/AC220V	LED	Flood/Spot	200W*4	84000lm	73kg			
CHL424250	DC12V/24V	AC220V	LED	Flood/Spot	250W*4	105000lm	75kg			
CHL424400	DC12V/24V	AC220V	LED	Flood/Spot	400W*4	168000lm	75kg			
CHX424600	DC12V/24V	AC220V	LED	Flood/Spot	600W*4	276000lm	73kg			
CHX424700	DC12V/24V	AC220V	LED	Flood/Spot	700W*4	322000lm	73kg			
CFA424150	DC12V/24V	DC12V/24V/AC220V	Metal halogen	Flood	150W*4	44000lm	73kg			
CHG424250	DC12V/24V	AC220V	Metal halogen	Flood/Spot	250W*4	80000lm	73kg			
CHG424400	DC12V/24V	AC220V	Metal halogen	Flood/Spot	400W*4	144000lm	73kg			
CHG424600	DC12V/24V	AC220V	Metal halogen	Flood/Spot	600W*4	180000lm	73kg			
CHG4241000	DC12V/24V	AC220V	Metal halogen	Spot	1000W*4	220000lm	73kg			

Telescopic Mast Light

SGN70-4600X

Special designed for fire-fighting & rescue vehicles, the fully self-developed night emergency lighting system has a lifting and rotating lighting function, adopts international leading design concepts and manufacturing processes, the lighting optics is patented by a professional optical team. The LED light source has high brightness, energy saving, and long life; lights starts without interference; it is safe and low voltage, pollution-free;

It has the characteristics of wired controller and wireless remote control, automatic reset, easy operation, high power, light weight, small size, high brightness, wide irradiation and long range. It can be quickly activated to provide high-brightness and emergency lighting for fire-fighting lighting, engineering rescue, disaster relief & police scenes.

System working voltage	DC12V/DC24V
Lamp working voltage	AC220V
Lamp power	600W*4
Lamp working current	≤12A
Rotating working current	≤2A (max)
Horizontal rotation angle	380°
Vertical rotation angle	180°
Rotating speed	4r/min
Luminous	252000lm
Working temperature	-40°~55°
Lamp protection grade	IP66
Lamp lighting form	Floodlight, level 70°
Light source	LED
Control Mode	Wired and wireless
Telescopic Mast	1950-7000m
Lifting power	Pneumatic
Rising time	≤2 min
Spring wire	Internal



Telescopic Mast Light

SGN70-2600

Special designed for fire-fighting & rescue vehicles, the fully self-developed night emergency lighting system has a lifting and rotating lighting function, adopts international leading design concepts and manufacturing processes, the lighting optics is patented by a professional optical team. The LED light source has high brightness, energy saving, and long life; lights starts without interference; it is safe and low voltage, pollution-free;

It has the characteristics of wired controller and wireless remote control, automatic reset, easy operation, high power, light weight, small size, high brightness, wide irradiation and long range. It can be quickly activated to provide high-brightness and emergency lighting for fire-fighting lighting, engineering rescue, disaster relief & police scenes.



System working voltage	DC12V/DC24V
Lamp working voltage	AC220V
Lamp power	600W*2
Lamp working current	≤6A
Rotating working current	≤2A (max)
Horizontal rotation angle	380°
Vertical rotation angle	180°
Rotating speed	4r/min
Luminous	126000lm
Working temperature	-40°~55°
Lamp protection grade	IP66
Lamp lighting form	Floodlight, level 70°
Light source	LED
Control Mode	Wired and wireless
Telescopic Mast	1950-7000m
Lifting power	Pneumatic
Rising time	≤2 min
Spring wire	Internal

Telescopic Mast Light

SGN70-41000X

Special designed for fire-fighting & rescue vehicles, the fully self-developed night emergency lighting system has a lifting and rotating lighting function, adopts international leading design concepts and manufacturing processes, the lighting optics is patented by a professional optical team. The LED light source has high brightness, energy saving, and long life; lights starts without interference; it is safe and low voltage, pollution-free;

It has the characteristics of wired controller and wireless remote control, automatic reset, easy operation, high power, light weight, small size, high brightness, wide irradiation and long range. It can be quickly activated to provide high-brightness and emergency lighting for fire-fighting lighting, engineering rescue, disaster relief & police scenes.



System working voltage	DC12V/DC24V
Lamp working voltage	AC220V
Lamp power	1000W*4
Lamp working current	≤12A
Rotating working current	≤2A (max)
Horizontal rotation angle	380°
Vertical rotation angle	180°
Rotating speed	4r/min
Luminous	420000 lm
Working temperature	-40°~55°
Lamp protection grade	IP66
Lamp lighting form	Floodlight, level 70°
Light source	LED
Control Mode	Wired and wireless
Telescopic Mast	1950-7000m
Lifting power	Pneumatic
Rising time	≤2 min
Spring wire	Internal



Telescopic Mast Light

SGN70-21000X

Special designed for fire-fighting & rescue vehicles, the fully self-developed night emergency lighting system has a lifting and rotating lighting function, adopts international leading design concepts and manufacturing processes, the lighting optics is patented by a professional optical team. The LED light source has high brightness, energy saving, and long life; lights starts without interference; it is safe and low voltage, pollution-free;

It has the characteristics of wired controller and wireless remote control, automatic reset, easy operation, high power, light weight, small size, high brightness, wide irradiation and long range. It can be quickly activated to provide high-brightness and emergency lighting for fire-fighting lighting, engineering rescue, disaster relief & police scenes.



System working voltage	DC12V/DC24V
Lamp working voltage	AC220V
Lamp power	1000W*2
Lamp working current	≤12A
Rotating working current	≤2A (max)
Horizontal rotation angle	380°
Vertical rotation angle	180°
Rotating speed	4r/min
Luminous	210000 lm
Working temperature	-40°~55°
Lamp protection grade	IP66
Lamp lighting form	Floodlight, level 70°
Light source	LED
Control Mode	Wired and wireless
Telescopic Mast	1950-7000m
Lifting power	Pneumatic
Rising time	≤2 min
Spring wire	Internal

Telescopic Mast Light

SG70-4120L

The SG series vehicle-mounted lifting lighting equipment is a night emergency lighting system designed for special medium and large vehicles. It lifting and rotating for full angle illumination.

It has the characteristics of wired controller and wireless remote control, automatic reset, easy operation and use, high power, high brightness, wide illumination range.

This product can provide emergency lighting for various applications such as fire-fighting lighting, engineering rescue, disaster relief, and police scenes.

System working voltage	DC12V/DC24V
Lamp working voltage	DC12V/DC24V
Lamp power	120W*4
Lamp working current	≤40A
Rotating working current	≤2A (max)
Horizontal rotation angle	380°
Vertical rotation angle	330°
Rotating speed	4r/min
Luminous	50400lm
Working temperature	-40°~55°
Lamp protection grade	IP66
Lamp lighting form	Floodlight, level 70°
Light source	LED
Control Mode	Wired and wireless
Telescopic Mast	1950-7000m
Lifting power	Pneumatic
Rising time	≤2 min
Spring wire	External



Telescopic Mast Light

SG70-4200L

The SG series vehicle-mounted lifting lighting equipment is a night emergency lighting system designed for special medium and large vehicles. It lifting and rotating for full angle illumination. High power lamps are used as the main light source.

It has the characteristics of wired controller and wireless remote control, automatic reset, easy operation and use, high power, high brightness, wide illumination range.

This product can provide emergency lighting for various applications such as fire-fighting lighting, engineering rescue, disaster relief, and police scenes.

System working voltage	DC12V/DC24V
Lamp working voltage	DC24V/AC220V
Lamp power	200W*4
Lamp working current	≤40A
Rotating working current	≤2A (max)
Horizontal rotation angle	380°
Vertical rotation angle	330°
Rotating speed	4r/min
Luminous	84000lm
Working temperature	-40°~55°
Lamp protection grade	IP66
Lamp lighting form	Floodlight, level 70°
Light source	LED
Control Mode	Wired and wireless
Telescopic Mast	1950-7000m
Lifting power	Pneumatic
Rising time	≤2 min
Spring wire	External



Telescopic Mast Light

SGN70-41000F

The SG series vehicle-mounted lifting lighting equipment is a night emergency lighting system designed for special medium and large vehicles. It lifting and rotating for full angle illumination. High power lamps are used as the main light source.

It has the characteristics of wired controller and wireless remote control, automatic reset, easy operation and use, high power, high brightness, wide illumination range.

This product can provide emergency lighting for various applications such as fire-fighting lighting, engineering rescue, disaster relief, and police scenes.

System working voltage	DC12V/DC24V
Lamp working voltage	AC220V
Lamp power	1000W*4
Lamp working current	≤20A
Rotating working current	≤2A (max)
Horizontal rotation angle	380°
Vertical rotation angle	330°
Rotating speed	4r/min
Luminous	80000lm
Working temperature	-40°~55°
Lamp protection grade	IP66
Lamp lighting form	Floodlight, level 70°
Light source	Halogen
Control Mode	Wired and wireless
Telescopic Mast	1950-7000m
Lifting power	Pneumatic
Rising time	≤2 min
Spring wire	Internal



Telescopic Mast Light

SGN70-41000G

The SG series vehicle-mounted lifting lighting equipment is a night emergency lighting system designed for special medium and large vehicles. It lifting and rotating for full angle illumination. High power lamps are used as the main light source.

It has the characteristics of wired controller and wireless remote control, automatic reset, easy operation and use, high power, high brightness, wide illumination range.

This product can provide emergency lighting for various applications such as fire-fighting lighting, engineering rescue, disaster relief, and police scenes.

System working voltage	DC12V/DC24V
Lamp working voltage	AC220V
Lamp power	1000W*4
Lamp working current	≤12A
Rotating working current	≤2A (max)
Horizontal rotation angle	380°
Vertical rotation angle	180°
Rotating speed	4r/min
Luminous	210000 lm
Working temperature	-40°~55°
Lamp protection grade	IP66
Lamp lighting form	Floodlight, level 70°
Light source	Metal Halogen
Control Mode	Wired and wireless
Telescopic Mast	1950-7000m
Lifting power	Pneumatic
Rising time	≤2 min
Spring wire	Internal



PLT826 search light



- ◆ High power 80W LED light, warning lights on the back of the lamp head
- ◆ Strong magnet base
- ◆ Shock resistance and impact resistance, IP66 protection level
- ◆ Suitable for various engineering lighting vehicles, patrol, fire trucks rescue cars and other special vehicles.

No.	Parameter		Unit	Value
1	Rated voltage		V	DC12-24
2	Light power		W	80W
3	Lamp style		/	Spotlight
4	Warning light color		/	Red/yellow/blue/Dual
5	Illuminance		Lx	> 12000 (at 5 meter)
6	Average life		h	100000
7	Effective irradiation distance		m	5000
8	Dimensions (L * W * H)	Up state	mm	307×280×332
		Lie down state		363×280×150
9	Weight		KG	5
10	Control mode	Remote	/	50 meter
		Wired	/	Optional choice
11	Rotation angle	Vertical	degree	180
		Horizontal		360
12	Waterproof		/	IP66

PLT828 search light



- ◆ 30W LED light, remote control
- ◆ Strong magnet base
- ◆ Shock resistance and impact resistance, IP65 protection level
- ◆ Suitable for various engineering lighting vehicles, patrol, fire trucks rescue cars and other special vehicles.

No.	Parameter		Unit	Value	
1	Voltage		v	12-24	
2	Lamps	LED	Power	w	30
			Illumination	lm	3500
			Life time	h	100000
			Lighting range	m	1500
3	Rotation	Vertical	degree	180	
		Horizontal	degree	≥360	
4	Remote distance		m	30	
5	Dimension	L x W x H	mm	310×265×350	
6	Weight	Whole device	kg	5.5	

Pneumatic Telescopic Mast

SG series

SG series mast is a telescopic mast pole specially designed for vehicle-mounted lighting equipment. The mast is fixed in the cabin or the periphery of the vehicle body, and vertically lifts lights, camera, antenna equipment, etc., to achieve customer predetermined functions.

SG series lifting mast can choose 3.5m-15m different height according to different requirements. If the scope of this range can not meet the work needs, we can customize according to your requirements.

Model	Pitch	Rising Height	Closing Height	Mounting Height	Mounting hole	Max diameter	Load weight	Diameter A3	Diameter A4	Mounting hole diameter
		L1m	L2mm	L3mm	diameter A1mm	A2mm		mm	mm	
SG35-1	3	3.5	1635	1520	Φ85	Φ133	80	Φ200	Φ230	4-Φ13
SG35-2	3	3.5	2010	1913	Φ34	Φ68	50	Φ105	Φ130	4-Φ11
SG45-1	4	4.5	1670	1520	Φ65	Φ133	80	Φ200	Φ230	4-Φ13
SG45-2	4	4.5	2170	2020	Φ65	Φ133	80	Φ200	Φ230	4-Φ13
SG55-1	4	5.5	1785	1630	Φ65	Φ133	80	Φ200	Φ230	4-Φ13
SG55-2	4	5.5	2225	2070	Φ65	Φ133	80	Φ200	Φ230	4-Φ13
SG65-1	5	6.5	1770	1570	Φ45	Φ133	80	Φ200	Φ230	4-Φ13
SG65-2	5	6.5	1950	1750	Φ45	Φ133	80	Φ200	Φ230	4-Φ13
SG65-3	4	6.5	2235	2080	Φ65	Φ133	80	Φ200	Φ230	4-Φ13
SG75-1	6	7.5	1790	1540	Φ45	Φ160	80	Φ200	Φ230	4-Φ13
SG75-2	6	7.5	1845	1595	Φ45	Φ160	80	Φ200	Φ230	4-Φ13
SG75-3	5	7.5	1990	1780	Φ65	Φ160	80	Φ200	Φ230	4-Φ13
SG75-4	5	7.5	2120	1915	Φ65	Φ160	80	Φ200	Φ230	4-Φ13
SG85-1	6	8.5	2015	1770	Φ45	Φ160	80	Φ200	Φ230	4-Φ13
SG85-2	6	8.5	2315	2070	Φ45	Φ160	80	Φ200	Φ230	4-Φ13
SG85-3	5	8.5	2300	2090	Φ65	Φ160	80	Φ200	Φ230	4-Φ13
SG100-1	6	10	2290	2040	Φ45	Φ160	50	Φ200	Φ230	4-Φ13
SG100-2	6	10	2300	2040	Φ65	Φ190	80	Square185×185	Square230×230	4-Φ13
SG100-3	7	10	2400	2100	Φ45	Φ190	80	Square185×185	Square230×230	4-Φ13
SG100-4	7	10	2400	2090	Φ65	Φ210	100	Square195×195	Square245×245	4-Φ17
SG120-1	7	12	2395	2095	Φ45	Φ190	80	Square185×185	Square230×230	4-Φ13
SG120-2	7	12	2400	2050	Φ65	Φ210	100	Square195×195	Square245×245	4-Φ17
SG120-3	7	12	2500	2050	Φ45	Φ190	80	Square185×185	Square230×230	4-Φ13
SG120-4	7	12	2500	2190	Φ65	Φ210	100	Square195×195	Square245×245	4-Φ17
SG150-1	7	15	2975	2615	Φ65	Φ210	80	Square195×195	Square245×245	4-Φ17
SG150-2	6	15	3200	2900	Φ85	Φ210	80	Square195×195	Square245×245	4-Φ17



Pneumatic Telescopic Mast

SGN series

The SGN series has spring wire inside the lifting mast, which convenient to use and install. And the appearance is more compact and beautiful.

The built-in spring wire is made of flame-retardant elastic material, which has the characteristics of high strength, good toughness, cold resistance, high temperature resistance, aging resistance, and abrasion resistance.

SGN masts made of high-strength aluminum alloy, the inner wall of the cylinder adopts a high-pressure wear-resistant porcelain treatment process, and the outer cylinder is round sandblasted and anodized. High level of sealing performance, the 24H lifting mast slides less than 20mm in a static state.

Model	Section	Extended height L1mm	Retracted height L2mm	Install height L3mm	Top fix hole A1mm	Max diameter A2mm	Max payload kg	Base plate A3 mm	Base diameter A4mm	Flange fix hole L4mm	Diameter of flange L5mm
SGN35-1	3	3500	1600	1365	81	112	60	Ø200	Ø230	Ø200	Ø230
SGN35-2	4	3500	1407	1120	81	133	60				
SGN45-1	3	4500	1950	1715	81	112	60				
SGN45-2	4	4500	1707	1420	81	133	60				
SGN55-1	3	5500	2300	2065	81	112	60				
SGN55-2	4	5500	1957	1670	81	133	60				
SGN65-1	4	6500	2200	1910	81	133	60				
SGN65-2	5	6500	2010	1670	81	160	60				
SGN75-1	5	7500	2150	1810	81	160	60				
SGN75-2	6	7500	2103	1710	81	190	60				
SGN85-1	5	8500	2450	2110	81	160	60	Ø200	Ø230	Ø200	Ø230
SGN85-2	6	8500	2303	1910	81	190	60	185*185	230*230	Ø230	Ø258
SGN100-1	6	10000	2550	2150	81	190	60	185*185	230*230	Ø230	Ø258
SGN100-2	7	10000	2456	2010	81	210	60	195*195	245*245	Ø270	Ø300



Manual winch lifting Mast SJ series

Manual winch lifting mast is mainly designed for lifting professional portable lighting equipment.

The mast can be fixed in the side of tripod or trailer. Regular extended heights are 3.5m, 4.2m, 5.0m, 5.5m and 6.0m. Specific requests can be customized.

Model	SJ-35SY	SJ-42SY	SJ-50SY	SJ-55SY	SJ-60SY
Closing height	1467	1700	1600	1580	2300
Extened height	3500	4200	5050	5500	6000
Sections	3	3	4	5	3
Max Diameter	60×60	60×60	80×80	90×90	60×60
Weight	≈12Kg	≈16Kg	≈18Kg	≈26Kg	≈20Kg
Rise mode	Manual winch				
Pay load	≤15kg				
Material	Stainless steel				



Electric Telescopic Mast

SGD series

This electric telescopic mast is driven by trapezoidal screw, lifting process is stable and reliable. With self-locking system, the mast can stop at any position as need.

There is rubber seal between each section of mast, tripled protection: anti-water, anti-sand, anti-icing.

Strong compact design ensures bending, torsion and 8 grade wind resistance.

Specifications:

Height CM/ Payload KG	Height (M)	Section	Closing height(M)	Max size (mm)	Vertical Payload (KG)	Horizontal Payload (KG)	Rising time (min)	Motor power (W)	Base size (mm)	Fix hole size (mm)	Weight (KG)
SGD40/50	4	3	1.58	99.5	50	10	2	180	315*164	345*194	40
SGD40/100	4	3	1.6	118	100	12	2	180	315*164	345*194	40
SGD60/50	6	4	1.82	118	50	10	3.5	180	315*164	345*194	50
SGD60/100	6	4	1.85	138.5	100	12	4.5	180	335*172	365*202	65
SGD80/50	8	5	1.98	138.5	50	10	5	180	335*172	365*202	70
SGD80/100	8	5	2.0	162	100	12	5	370	380*194	350*164	90
SGD100/50	10	6	2.1	162	50	10	5.5	370	380*194	350*164	100
SGD100/100	10	6	2.16	189	100	12	5.5	370	380*194	350*164	140
SGD120/50	12	7	2.22	189	50	10	5.5	370	380*194	350*164	125
SGD120/100	12	7	2.3	230	100	12	5.5	750	500*280	530*310	265
SGD150/50	15	7	2.74	230	50	10	7	750	500*280	530*310	265
SGD150/100	15	8	2.62	275	100	12	6	750	500*280	530*310	320
SGD185/50	18.5	8	3.0	275	50	10	7.5	750	500*280	530*310	355
SGD180/100	18	8	3.0	326	100	12	10	750	595*374	625*404	460
SGD198/50	19.8	9	3.0	326	50	10	9.5	750	595*374	625*404	465



Vehicle Mounted Collapsible Mast

PTZ, camera, lighting equipment and antenna could be fixed on top of the device.

The device has a 0-90 degree lodging function and can always keep the top platform at horizontal status.

CD10 Lodging Equipment

Model:	CD10
Working voltage:	DC12V/DC24V
Extended Height:	1 meter (39.3 inch)
Moving angle:	0-90°
Platform:	Horizontal
Remote control:	Available
Material:	Aluminum housing
Weight:	18kg



CD50 Lodging Equipment

Model:	CD50
Working voltage:	DC12V/DC24V
Extended Height:	2-5 meter
Moving angle:	0-90°
Platform:	Vertical
Remote control:	Available
Material:	Aluminum housing
Weight:	25-80kg

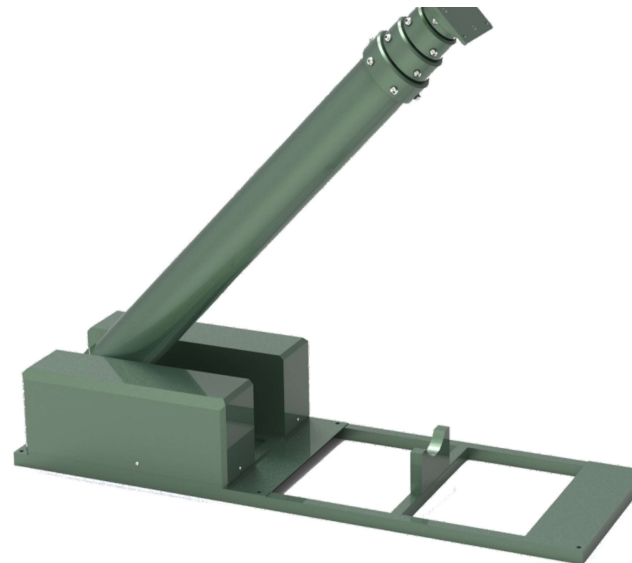

Antenna Smart PTZ

Y06 heavy duty PTZ

Lodging device specially designed and developed for install antenna.
It has one-button automatic reset function, reliable performance and easy operation.
Vertically 0-90 degrees, at a speed of 1r/min.
Optional: manual lodging function, can work by manual shaken when there is no power supply.

Voltage	DC12V
Current	≤ 10 A
Rotary degree	0-90
Rotary speed	1r/min
Pay load	8.5Kg



Y01 Light weight PTZ

Lodging device specially designed and developed for install antenna.
It has one-button automatic reset function, reliable performance and easy operation.
Vertically 0-90 degrees, at a speed of 4r/min.

Voltage	DC12V
Current	≤ 3A
Rotary degree	0-90
Rotary speed	4r/min
Pay load	6.5Kg



Fittings: Vehicle roof Mount bracket

Medium size type

- ★ Stable, beautiful and steady.
- ★ high-strength aluminum profile, light weight, strong oxidation resistance.
- ★ Installed without drilling, with top support hooks.
- ★ The four legs are adjusted according to the width and arc of the vehicle.

Dimension	1000 x 1100mm(or customized)
Material	Aluminum alloy
Upper brackets	2 pieces
Lower brackets	2 pieces
Legs	4 pieces
Fixing	Via hook



Small size type

- ★ Stable, simple and steady.
- ★ high-strength aluminum profile, light weight, strong oxidation resistance.
- ★ Installed without drilling, with top support hooks.

Vehicle type	Car, pick up, truck
Material	Cold rolled steel
Color	Black
Legs	4 legs
Brackets	2 pieces
Fixing	Via hook



Smart control system

- ★ Use for vehicle-mounted mast lighting equipment.
- ★ Optional functions: Mast rise, drop, stop; rotate; light on & off; camera zoom, protective wiper.
- ★ The controller has two working modes: wired control and wireless remote control.
- ★ When wired, connect and charge the battery. When unplugged, remote operation can be realized.
- ★ The controller is equipped with a LED display screen, which providing equipment status, instructions, error reports.

Rated voltage	DC12V
Battery	400MAH/3.7VDC
Remote working time	≤4H
Working temperature	-20~55℃
Protection level	IP55
Dimension	150X75X20mm



Smart warning & lighting system

- ★ Combined with warning lightbar, display message screen, mast lighting system, camera.
- ★ Smart vehicle mobile & 4G remote monitoring.
- ★ The controller has two working modes: wired control and wireless remote control.
- ★ High power brightness for night emergency lighting and video recording.
- ★ Multifunctional for police commander process.

Mast Lighting	Mast height: 1.8-3.5 meter
	Lamps: 2 x 120W (can customized)
	Full angle lighting
	Control mode: wired & remote
Recording camera	Focal length: 30 times
	Effective pixels: 3 million
	External interface: network port, RS485
Camera sheel	Aperture : F1.6-F4.4
	Constant temperature, fan + heater Wiper included
4G DVR	Video and audio input: 5 channels
	VGA output: 1 way
	Storage hard disk: 2 x 2.5 in, the maximum capacity: 2TB
	4G module: optional
Control keyboard	Display size: 7 inches
	Resolution: 1024*600
	Input plug: VGA



Portable Lighting products

PLT622 Firefighter Flashlight

Intrinsically safe explosion-proof grade, meeting the requirements of safe work in zone I and II.

Unique patented explosion-proof switch structure design, more convenient to use and operate.

High-capacity lithium battery, large capacity, long life, low self-discharge rate, economical and environmentally friendly.

The humanized dual power indicator and low-voltage warning function design can intuitively check the remaining battery power at any time.

No.	Parameter		Unit	Value
1	Rated voltage		V	3.7
2	Rated capacity		Ah	1.6
3	Light(LED)	Rated power	Strong light	3
			Work light	1
	Current	Strong light	600	
		Work light	220	
	Luminous	Strong light	≥480	
		Work light	≥120	
Continuously lighting time	Strong light	5		
	Work light	10		
4	Charging time		h	6
5	Average life time		h	≥100000
6	Battery life time		times	1000
7	Dimension	Diameter×Length	mm	23×116
8	Weight		g	86



PLT635 Handheld Explosion Proof Search Light

Full accordance with national explosion-proof standards, and can work safely in various flammable and explosive places.

The lamp adopts professional sealing design, protection grade IP66/67, which meets the requirements of fire protection standards and is used in various harsh environments.

Has a low-voltage warning function and a 5-segment LED power display device at the rear, which can visually display the battery power in real time

No.	Parameter		Unit	Value	
1	Rated voltage		V	22.2	
2	Rated capacity		Ah	2.5	
3	Rated power		W	12	
4	Light	Working voltage		V	22.2
		Current	Strong light	A	0.95
			Work light		0.45
		Luminous	Strong light	lm	16000
			Work light		6000
Average life time		h	100000		
5	Continuously light time	Strong light		≥8	
		Work light		13	
		Strobe light		100	
6	Charging time		h	<6	
7	Battery life time		times	1000	
8	Dimension	Length		305	
		Diameter Ø		86	
9	Weight		kg	1.4	
10	Explosion mark		Exd ia IICT6 Gb		
11	Protection level		IP66/67		



PLT910 Explosion Proof Flashlight

Full accordance with national explosion-proof standards and can work safely in various flammable and explosive places.

Lightweight high-hardness alloy shell can withstand strong collisions and impacts, fully sealed design, can be immersed in water test.

Battery power query and low-voltage warning function design, you can check the remaining battery power at any time.

The outer surface has deep anti-skid treatment, compact structure, light weight, simple and convenient operation and beautiful appearance.

No.	Parameter	Unit	Value	
1	Rated voltage	V	3.7	
2	Rated capacity	Ah	2.2	
3	Rated power	W	3	
4	Light	Current	mA	600
		Luminous	lm	390
		Average life time	h	≥100000
5	Continuously lighting time	Strong light	h	10
		Work light	h	20
6	Charging time	h	≤6	
7	Battery life time	times	≥1000	
8	Dimension	Length	mm	157
		Diameter Ø	mm	35
9	Weight	g	≤220	
10	Explosion mark	ExdIICT6		
11	Protection level	IP67		



PLT892 Multi-function Mobile Lighting System

Small size, light weight. It is telescopic, portable and wearable. When used on a rail system, its bottom mounted rail wheel which can be used to facilitate long distance movement on the rail.

According to the requirements of the lighting height to lift the lights manually. The maximum height is 1.8 meters.

Each lamp is able to do 360-degree vertical and horizontal rotation, providing multi-angle lighting needs.

Compatibility, equips a standard USB charging interface for mobile phones and other digital products.

No.	Parameter		Unit	Value
1	Battery rated voltage		V	DC25.9
2	Battery rated capacity		Ah	22
3	Lighting method			Spotlight / Floodlight
4	Continuous lighting time	Floodlight lighting time	H	≥12
		Spotlight lighting time	H	≥22
		Spotlight / Floodlight	H	≥8
5	Charger input voltage		V	AC220V
6	Camera Pixel		M	8
7	Camera / Picture Format		/	MP4/JPG
8	Camera storage capacity		G	32
10	Warning light color		/	Red/yellow/blue
12	Power amplifier board (speaker) power		W	30
13	Battery life		cycle	About 500 times
14	Charging time		H	≤6
15	Dimensions (L * W * H)	Shrinking state	MM	350×326×620
		Rise state	MM	350×326×1845
16	Weight		KG	16
17	Use the ambient temperature		℃	-20~40
18	Protection level	Waterproof (light head)	/	IP65
		Waterproof (Box body)	/	IP54



PLT893 Portable Working Lamp

Compact design with strong strength plastic material,whole set is only 8kg,easy to carry.

Collapsible mast can be deployed and retracted manually,1.5m extended height.

Inbuilt USB interface can charge your mobile phone,camera freely outside.

Visible LCD screen shows lighting modes and battery status,10%-100% dimmer switch available.

Equipped Red/Yellow warning lighting system ensure the operator safety.



No.	Parameter		Unit	Value
1	Rated battery voltage		V	21.6
2	Rated capacity		Ah	13.2
3	LED Light	Working voltage	V	18-26
		Light power	W	35
		Luminous	lm	4800
		5 meter center intensity	Lx	1100
		Average life time	h	100000
4	Flood and spot lighting time		h	8
5	Spot lighting time			20
	Flood lighting time			12
6	Charging time	Battery working	h	≤8
7	Battery life time		circle	≥500 times
8	Warning light color		/	Red/Amber
9	Dimension	Retract	mm	510*290*220
		Extend		510*290*1500
10	Weight		kg	8
11	Protection level	Lamp	/	IP65
		Body		IP54

PLT898 Portable Working area Light

- ★ Compact design with strong strength plastic material, easy to carry
- ★ Collapsible mast can be deployed and retracted manually, 4meter extended height.
- ★ Visible indicator lighting brightness, bluetooth and app remote control
- ★ Explosion-proof structure design, and the overall protection level reaches IP66
- ★ Three lamps for full angle lighting adjustment, power reach to 180W

Code	Specification			
1	Rated voltage	V	DC22.2	
2	Battery capacity	Ah	25	
3	LED light	Rated power	W	180
		Life time	h	100000
		10m illumination	Lx	600
4	Type	/	Flood + Spot	
5	Warning light	/	Red-blue	
6	Lighting time (Flood + Spot)	Strong	h	≥ 6
		medium		≥ 9
		Dim		≥ 12
7	Battery life time	times	> 500	
8	Charging time	h	< 5	
9	Dimension	Pack up	mm	200*222*1155 (± 20)
		Extended		780*780*4000 (± 20)
10	Weight	Kg	13 \pm 1	





Lightbar Series

TBD-5H905



Item No	TBD-5H905
Voltage	12V / 24V DC (choose one)
Product Description	3W LED, 3pcs/module, 22 LED modules
	Without speaker, with light controller ECE R65 certificated
Color	Red, Blue, Amber, White
Flash patterns	Multi flash patterns (can customized)
Material	PC Lens & Aluminum base
Operating Temperature	-40 to 55°C
Product Size/N.W.	1200*300*126mm/10.5kgs

TBD-8H406



Item No	TBD-8H406
Voltage	12V / 24V DC (choose one)
Product Description	1W/3W LED, 6pcs/module, 18 LED modules
	Center 100W speaker or without speaker
Color	Red, Blue, Amber, White
Flash patterns	Multi flash patterns (can customized)
Material	PC Lens & Aluminum base
Operating Temperature	-40 to 55°C
Product Size/N.W.	1185*300*100mm/12kgs
Light thickness	62mm

TBD-8H908



Item No	TBD-8H908
Voltage	12V / 24V DC (choose one)
Product Description	1W/3W LED, 6pcs/module, 26 LED modules
	1.4 meter (as photo shows), 1.2/1.6/1.8 meter can do, without speaker
Color	Red, Blue, Amber, White
Flash patterns	Multi flash patterns (can customized)
Material	PC Lens & Aluminum base
Product Size/N.W.	1420*300*100mm/10.5kgs
Light thickness	62mm

TBD-A505

New type LED lightbar, high power LED as light source. Upper and base aluminum for strong structure and heat dissipation. Widely used for public police, firefighting, engineering, ambulance, highway, electric power and other special vehicles.



Item No	TBD-A505
Voltage	12V / 24V DC (choose one)
Product Description	1W/3W led light, 4 ea/module,22 modules
	With digital controller
	With siren speaker ,controlled by siren
	With 2 Mounting Brackets and hooks
LED Color	Red,Blue,Amber,White,Green
Aluminum Color	White / Black / Silver
Flash patterns	More than 15 patterns
Material	PC Lens & Aluminum body

TBD-A525

New type LED lightbar, two layer high power LEDs. Upper and base aluminum for strong structure and heat dissipation. Widely used for public police, firefighting, engineering, ambulance, highway, electric power and other special vehicles.



Item No	TBD-A525
Voltage	12V DC
Product Description	1W led light, 8 ea/module,22 modules
	With digital controller
	With 2 Mounting Brackets and hooks
LED Color	Red,Blue,Amber,White,Green available
PC Color	Transparent
Aluminum Color	White,black available
Flash patterns	More than 15 patterns
Material	PC Lens & Aluminum Base

TBD-A815

Super slim design, high power LED as light source. Upper and base aluminum for strong structure and heat dissipation. Widely used for public police, firefighting, engineering, ambulance, highway, electric power and other special vehicles.



Item No	TBD-A815
Voltage	12V DC
Product Description	Front and Rear: 12pcs x 16 Modules
	End: 3pcs x 6 Modules
	With digital controller
Led Color	Red,Blue,Amber,White,Green Available
Lens Color	Transparent
Flash patterns	26 type flashing patterns
Material	PC Lens & Aluminum Body

Warning lightbars for police

This series of lightbars are mostly designed and developed for public security and police use, using the most popular, most visually impactful, energy-saving, environmentally friendly and high-efficiency high-brightness LED as the main light source, exerting a strong deterrent and warning effect.

Red is the primary color in the warm color system and has a warning effect, while blue is the primary color in the cool color system, which is in sharp contrast with red and can attract people's attention.

The warning light and siren are integrated for easy installation and operation; the shape of the whole light is perfectly combined with the main warning light.



A16



A15



A70



A30



A20



A20



A55



A17



A50



A35

Warning Lightbars for Firetrucks

These lightbars mostly designed and developed for fire-fighting vehicles, EMS rescue cars. Use visually impactful, energy-saving, environmentally-friendly and high-efficiency high-brightness LED as the main light source, exerting a strong deterrent effect.

Red is the primary color in the warm color system. It has the most warning effect and can attract people's attention. It has a very strong emergency warning effect on fire-fighting vehicles and vehicle driving.

The warning light and siren are integrated for easy installation and operation; the shape of the whole light is perfectly combined with the main light.



Small Warning Beacon series

JSY-13X

The light source adopts low-power or high-brightness high-power LED light-emitting tube, which has long life, low power consumption, strong fog penetration ability, no heat, stable and reliable. Suitable for use in large vehicles and public security booths.



Item No	JSY-L13	
Voltage	DC10-30V	
Description	12pcs 1.5W 3030 LEDs	
	129.8*89*97mm	
	3 bolts mount and magnet mount	
Led Color	Red,Blue,Amber,White,Green	
Lens Color	Red,Blue,Amber,transparent	
Flash patterns	28 flash patterns (or only one)	
Materials	PC lens cover, ABS base	
Cable	3 meter	

JSY-615

The light source adopts low-power or high-brightness high-power LED light-emitting tube, which has long life, low power consumption, strong fog penetration ability, no heat, stable and reliable.



Item NO.	JSY-615L1	JSY-615L2
Rated voltage	12V / 24VDC	
Light description	72pcs/0.25W LEDs	8pcs 1W LEDs
	Φ170*140mm	Φ110*128mm
	Magnet mount	
LED color	Red,Blue,Amber,White,Green	
Lens color	Red,Blue,Amber,White, red-blue	
Material	PC lens, magnet base	

JSY-718

Made of high light-transmitting materials, high transparency. Suitable for large and medium vehicles, security booths and other places.



Item No	JSY-718	
Voltage	DC10-30V	
Description	72 ea 0.25W LEDs	
	175 x 95mm	
	3 bolts mount	
Led Color	Red,Blue,Amber,White,Green	
Lens Color	Red,Blue,Amber,transparent	
Flash patterns	Cycle flash	
Materials	PC lens cover, ABS base	
Cable	3 meter	

JSY-613

The light source adopts low-power or high-brightness high-power LED light-emitting tube, which has long life, low power consumption, strong fog penetration ability, no heat, stable and reliable.



Item No	JSY-613L1	JSY-613L3
Voltage	12V / 24VDC	10V-30VDC
Description	Led light ,0.25w led	18pcs 1W/3W LEDs
	Magnet mount	
Led Color	Red,Blue,Amber,White,Green	
Lens Color	Red,Blue,Amber,transparent	
Material	PC Lens & Magnet Base	
Dimension	Φ163mm, 132mm height	

JST-855 295

High efficiency and energy saving of ultra-high brightness LED with high precision constant current circuit design.
Bright, stable and longer life.



Item NO.	JST-855	JST-295
Rated voltage	12V / 24V DC (Choose one)	
Light description	0.05W LEDs	44 ea 0.05W LEDs
	270*210*50mm 200*100*43mm	
	Surface screw mount	
Color	Red,Blue,Amber,White,Green	
Material	PC lens with Chrome base	
Cable	1 meter long	

JST-833

Made of high light-transmitting materials, with high transparency.
Suitable for installation at ambulances, fire trucks and other special modified vehicles.



Item NO	JST-833
Voltage	12V / 24V DC (choose one)
Product Description	0.25w led light ,20 ea
Power Consumption	≤2W
Led Color	Red,Blue,Amber,White,Green
Lens Color	Red,Blue,Amber,transparent
Material	PC Lens & Chrome Frame
Product Size/N.W.	108*90.5*33mm

JST-141/142

High efficiency and energy saving of ultra-high brightness LED
Small size, easy to install, high brightness
Suitable for installation at ambulances, fire trucks and other special modified vehicles.



Voltage	10V-30V DC
Product Description	6 LEDs / 12 LEDs
LED Color	Red,Blue,Amber,White, Green
PC Dome Color	Transparent
Flash patterns	22 types
Material	PC Lens
Product Size	129*31,5*17,5/121*47,5*14,5mm

JST-6691

Small size, easy to install, a variety of surface mount methods are combined to perfectly combine with different car body surfaces.
With a variety of appearance colors, the product effect is more abundant.
Mainly suitable for vehicle installation applications such as cars, urban small SUV, etc.



Voltage	10V-30V DC
Product Description	1W/3W led light ,6 pcs
LED Color	Red,Blue,Amber,White, Green
PC Dome Color	Transparent
Flash patterns	22 types
Material	PC Lens & aluminum base
Product Size	170*35*28mm

Electronic Sirens

CJB-100

- *Controlled by a single-chip microcomputer, with clear sound quality and strong anti-interference ability
- *Ultra-thin streamlined design, classic style
- *Widely used for public police, EMS rescue, firefighting, engineering, ambulance, highway, electric power and other special vehicles.



Rated voltage	12V / 24V DC (Choose one)
Product description	With sound volume adjustment function
	With two light control button
	With handle microphone
	Tones: Wail-1, Wail-2, yelp, Hi-Lo, traffic, Pulsar, Horn, Horn-1, Siren
Output power	100W(and 80W, 150W, 200W, 300W)
Output resistance	8 ohms
Product Size	145*140*38mm

CJB- T1

- *Microcomputer chip control, stable alarm tone frequency
- *Split structure, effectively separates the control system from the host
- *Handle-type controller, which is convenient for installation and operation, and has warning light control function



Rated voltage	12V / 24V DC (Choose one)
Product description	With sound volume adjustment function
	With two light control button
	With handle controller
	Tones: Horn, Air horn, Wail, Hi-Lo, pulsar Yelp, Tool, MP3, Bluetooth, USB
Output power	100W(and 80W, 150W)
Output resistance	8 ohms
Product Size	140 * 140 * 5.3mm

CJB- T3

- *Microcomputer chip control, stable alarm tone frequency
- *Split structure, effectively separates the control system from the host
- *Handle-type controller, which is convenient for installation and operation, and has warning light control function



Rated voltage	12V / 24V DC (Choose one)
Product description	With sound volume adjustment function
	With two light control button
	With handle controller
	Tones: Horn, Air horn, Wail, Hi-Lo, pulsar Yelp, Tool, MP3, Bluetooth, USB
Output power	100W(and 80W, 150W)
Output resistance	8 ohms
Product Size	140 * 140 * 5.3mm

YP100-2B Loudspeaker

Built-in magnetic steel mixed rare earth material can resist high temperature.
Waterproof, corrosion resistance, and good air-tightness.



Item NO.	YP100-2B
Output power	100W/150W
Output Impedance	4.2 Ω/6 Ω/8 Ω/11 Ω
Sound compression	125-130 dB
Sound frequency	400-5000Hz
Distortion	≤5%

YP100-3C Loudspeaker

Newly developed ultra-thin polygon speaker.
It can be installed separately, with novel appearance and clear sound.
Good sealing, waterproof and dust-proof functions.



Item NO.	YP100-3C
Output power	100W/150W
Output Impedance	4.2 Ω/6 Ω/8 Ω/11 Ω
Sound compression	121-128 dB
Sound frequency	400-5000Hz
Distortion	≤5%

YP100-21 Loudspeaker

Newly developed ultra-thin polygon speaker.
It can be installed separately, with novel appearance and clear sound.
Good sealing, waterproof and dust-proof functions.



Item NO.	YP100-21
Output power	100W/150W
Output Impedance	4.2Ω/6Ω/8Ω/11Ω
Sound compression	123-129 dB
Sound frequency	400-5000Hz
Distortion	≤5%

YP100-22 Loudspeaker

Newly developed ultra-thin polygon speaker.
It can be installed separately, with novel appearance and clear sound.
Good sealing, waterproof and dust-proof functions.



Item NO.	YP100-22
Output power	100W/150W
Output Impedance	4.2 Ω/6 Ω/8 Ω/11 Ω
Sound compression	121-128 dB
Sound frequency	400-5000Hz
Distortion	≤5%

LED display screen series

XSP-1960X200 Message board

The induction screen can be widely used in public security, fire protection, traffic police, patrol police on duty, engineering rescue, on-site accident investigation, etc.

Mobile workplaces are used for information release and graphic warnings. Adopt the recommendations of relevant departments for design production.

This product has the characteristics of novel design structure, beautiful appearance, simple and convenient operation, multifunctional.



Product dimension	1960*200mm
Screen dimension	1920*160mm
Rated voltage	DC12V/24V
Working voltage	DC12V±10% (DC24V±10%)
Working temperature	-30℃ ~ +70℃
Control mode	1. Handle controller
	2. PC
	3. Mobile APP
	4. U disk
Pixel tube space	10 mm
Color of luminous	1R
Pixel faulty rate	<1/100000
Visual distance:	200-350 meters
Life Time	>100000 Hours

XSP-P10 Long-distance traffic guidance screen

1- High brightness, large viewing angle, adjustable luminous brightness, to meet the LED display screen can be effectively displayed in various environments such as sunlight, night, fog, rain and so on.

2-The bracket can be raised and lowered and contracted; it is convenient to carry and move.

3-Provide road information, play the role of road language; command and control traffic, ensure traffic safety; guide the way, improve driving efficiency.

Parameters:

- | | |
|--|--|
| 1. Screen size: 690*340*60mm | 11. Pixel composition: 1R |
| 2. Weight: 9KG | 12. Module resolution: 32*16 |
| 3. Power supply: 12V (AC, DC power supply available) | 13. Maximum power (W/m ²): 700 |
| 4. Current: 1.5 A/max | 14. Average power (W/square meter): 200-300 |
| 5. Working temperature: -30°C — +70°C | 15. Brightness (cd/square meter): ≥3500 |
| 6. Charging time: 5-8 hours | 16. Drive mode: constant voltage drive (1/4) |
| 7. Working time: 15-18 hours | 17. Refresh rate: 480HZ |
| 8. Module size (mm): 340 x 160mm | 18. IP protection level: IP65 |
| 9. Pixel pitch (mm): 10mm | 19. LED display viewing distance: 200-350 meters |
| 10. Pixel density (dots/square meter): 1000 | 20. The brightness uniformity of the display module: <5% |



Acoustic device series

HS-200D acoustic speaker 200W

- (1) Voice transmission distance 1000 meters, suitable for expressway remote sound reinforcement and emergency weather forecast;
- (2) Special places such as wildlife sanctuary, chemical industry, power station, strict traffic control area, airport, etc.;
- (3) All-weather design, the shell made by aerospace industry technology, is resistant to acid and alkali, salt spray, and can withstand high-strength impact and vibration;



Rated power	200W
Input voltage	70/100V
Rated impedance	4Ω/8Ω
Frequency range	300-10000
Sensitivity	116 dB±3
Maximum sound pressure	140 dB±3
Beam width(H×V)	15° ×30° @2.5kHz/-6dB
Speech intelligibility (STIPA)	0.8
Dimension	440×665×255(mm)
Net weight	22kg
Protection level	IP56

HS-330 HD audio horn 30W

- (1) All-weather design, suitable for indoor and outdoor
- (2) High-definition design, strong language clarity and bright sound
- (3) The transmission distance is long, and it can still be heard clearly at 500 kilometers in the open field.
- (4) Suitable for military long-distance broadcasting and large venues with long reverberation time.



Rated power	30W
Input voltage	70/100V
Rated impedance	4Ω/8Ω
Frequency range	250-8000 (-20dB)
Sensitivity	108 dB±3
Maximum sound pressure	123 dB±3
Beam width(H×V)	90° ×100° @1kHz/-6dB
Voice transmission distance	300m
Speech intelligibility (STIPA)	0.85
Dimension	315×207×368(mm)
Net weight	4.6kg
Protection level	IP56

HS-350 long distance amplifier system

Features:

1. Control system for amplifier
2. With sound source of wail-1, wail-2, dispersal, Yelp, Hi-lo, siren
3. Individual microphone volume control
4. Soft start design, reduce peak impact when starting up, reduce noise interference
5. Overload automatic intelligent protection function
6. Power supply high and low voltage protection function, 10.8V low voltage protection, 36V high voltage protection
7. The appearance design is miniature and concise, with stable performance and sufficient power, suitable for use in military broadcasting places

Parameters:

1. Rated voltage: DC12V/DC24V (AC220V available)
2. Live recording available
3. Output voltage: 100V
4. Output power: 350W
5. With ACC adaptive cruise control function
6. With LCD display, USB, SD card, Bluetooth playback control function



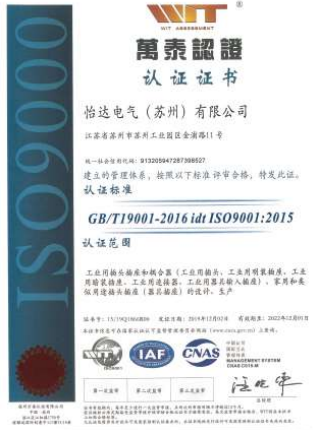



PULAITE
浦涑特

温州市浦涑特科技有限公司
WENZHOU PULAITE TECHNOLOGY CO., LTD

Tel : 0577-56565255

Mail : info@pulaite.com.cn

[https:// www.pulaitecorp.com](https://www.pulaitecorp.com)

Add: No.77 Jinyang Road, Wenzhou, China